

Operating Instruction Manual for
Q2 Quadrupole Magnet

Drawn	Approved
10-24-2003 S. Okada	

Operating Instruction Manual for Q2 Quadrupole Magnet

(1) System Specification

Table 2 shows the Q2 quadrupole magnet system specifications. Table 3 shows the Q2 quadrupole magnet design elements.

(2) System Structure

The structure of each component of the Q2 quadrupole magnet is described below.

(a) Core

The core consists of an upper core and a lower core with the left and right sides integrated into a single unit, and is tightened with supports that support the upper and lower cores, and bolts. Each core is manufactured by machining soft magnetic iron sheets.

The top surface of the upper core is designed with a machined measurement reference surface and target hole ($\phi 20H7$) in two locations.

(b) Coil

The coil area consists of one coil per magnetic pole, with a total of four coils per unit. Each coil is made from a hollow conductor ($8 \times 8 - \phi 6$) wound 64 times, and is sufficiently insulated. The coils are incorporated in the magnetic pole of the core and are supported by coil support fixtures.

In addition, a temperature switch is provided on the side of the cooling water outlet of each coil.

(c) Piping

The coil cooling water piping is established on the magnet side surface.

The coil cooling water piping consists of a water supply manifold, water discharge manifold and a connector-attached rubber hose.

The water supply manifold consists of a stop valve from upstream, a strainer and a flow control valve, and the water discharge manifold consists of a contact-attached flow gauge and stop valve. The attaching mechanism is a flange (ISO 25A). The coil fitting and rubber hose fitting, and water supply/discharge manifold and rubber hose fitting connections employ a gasket seal method with PF threading.

(d) Wiring

(i) Coil Electrical Wiring

The coil electrical wiring is connected to the lower left coil, lower right coil, upper right coil and upper left coil in series, in that order, and is equipped with terminals on both ends.

Each terminal is engraved or sealed with the label J or K, allowing you to verify connection with the power source, connecting + (positive) to J and – (negative) to K.

(ii) Measurement Instrument Wiring

The temperature switch and flow switch wiring is connected in series using a terminal block, and is connected to the interlock attachment mechanism of the electromagnetic power source from the terminal blocks. In the event an error is detected, the interlock to the electromagnetic power source is activated and the power is shut off. In the unlikely event an abnormality occurs, the cause of the abnormality may be one of the following. Check each cause accordingly.

- | | | |
|---|---|---|
| [1] Low cooling water flow | : | Check the flow gauge attached to the piping. |
| [2] Current error | : | The error may be due to overcurrent. Check the power supply. |
| [3] Measurement instrument wiring short | : | Check the terminal lead wires using a tester or other instrument. |
| [4] Measurement instrument malfunction | : | Contact Mitsubishi Electric. |

If the measurement instrument wiring was disconnected as the result of electromagnet disassembly or the like, verify that the wiring is wired as indicated in the final drawings.

(e) Stand (with Position Adjuster)

The stand is equipped with a position adjusting mechanism, and is designed with enough rigidity to withstand the weight of the electromagnet.

The position adjusting mechanism consists of a vertical adjuster used to adjust the position in the vertical direction, and a horizontal adjuster (movement: $\pm 15\text{mm}$) used to adjust the position in the horizontal direction (both ways) (movement: $\pm 15\text{mm}$). Each of the adjusters comprises a push-bolt structure, allowing you to achieve the required amount of movement by turning the bolt left or right. After the unit has been moved as required, lock the bolts with the nuts to keep the bolts from turning. Additionally, be sure to apply lubricating oil to the bolt contact surface to prevent rust in the event the unit is left out for a long period of time. Once the electromagnet is installed, tighten the core bolts to lock the electromagnet and stand.

(3) Maintenance and Replacement Parts

The maintenance and replacement parts and respective delivery guidelines are indicated below.

Table 1 Q2 Quadrupole Magnet Maintenance and Replacement Parts

No.	Part Name	Application	Quantity	Specifications	Delivery	Supplier
1	Flow switch	For interlock	1	FC-SD70-1R1-B30-0.5MPa (G) / 70°C-304-05-VP (1.5MPa (G))	A	Tokyo Flow Meter
2	Temperature switch	For interlock	8	UP72 (80 \pm 5°C)	A	Uchiya Thermostat
3	Rubber hose	For piping	16	3/8B	A	Togawa Rubber
4	Copper gasket	For piping	32	T2-0D15 x ID9 (3/8B)	A	Togawa Rubber
5	Lead wire and terminal block	For measurement instrument wiring	1 set	2mm ²	B	
2	Coating	Core	1 set	Munsell 2.5RP4/12 (Purple) JPMA : A92-40V	B	
3	Coating	Stand	1 set	Munsell 5Y7/1 (Gray) JPMA : A25-70B	B	
4	Coating	Magnetic pole	1 set	Epoxy varnish (Mitsubishi)	A	

The codes pertaining to part delivery in the table above are defined as follows:

Code A: Ordered by user by contacting Mitsubishi Electric. To order the part, contact Mitsubishi Electric with the following information:

- [1] Product serial number (stated on the faceplate)
- [2] Maintenance/replacement part name
- [3] Maintenance/replacement part specifications (See the above table.)
- [4] Maintenance/replacement part required quantity

Code B: Purchased by user according to the specifications stated in the table above.

(4) Operation and Maintenance Inspections

(a) Installation

Install the electromagnet (with stand) in the predetermined location. Verify that the stand is level prior to installation since the electromagnetic is placed on the stand. Secure the electromagnet by fully tightening the stand installation bolts.

Once the electromagnet is installed, connect the cooling water piping, electrical wiring and measurement instrument wiring. After you have installed the cooling water piping, execute flashing. After you have installed the electrical wiring, be sure to install the terminal cover.

And, after you have connected the measurement instrument wiring, verify that the instruments are interlocked with the electromagnet power source error status.

(b) Position Adjustment

Set the locator jig on the pole surface of the lower core and adjust the position by operating the vertical position adjuster and horizontal position adjuster with respect to the target position. Take sufficient care not to damage the thread sliding area when operating the adjusters. After adjustment is completed, tighten the core bolts to lock the electromagnet and stand.

(c) Electromagnet Operation

- [1] First, introduce pure water for coil cooling into the system. Maintain the cooling water flow at 50 [l/min] or higher. Check the flow rate using the contact-attached flow gauge installed on the electromagnet stand.
- [2] After you have checked the flow rate, turn on the switch to activate the electromagnet. Check conditions such as the current and voltage using a separate power source unit.
- [3] Verify that the system is free of defects such as abnormal noise, abnormal vibration and abnormal heat generation during operation.

(d) Suspending the Electromagnet

When you wish to suspend the electromagnet (with stand) in order to perform such actions as movement of the entire unit or electromagnet replacement, be sure to install the transport fixture, attach the established eye-bolt to the upper area of the core, run the wire rope through the eye-bolt and lower the crane steadily. Maintain a 60° wire rope opening. Prior to suspending the electromagnet, be sure that the following procedures have been performed:

- [1] Remove the cable connected to the coil electrical terminals.
- [2] Remove the cooling water piping connection mechanism.
- [3] Disconnect the measurement instrument wiring attached to the terminal blocks.
- [4] Remove the installation bolts between the electromagnet stand and common stand.

In addition, be careful not to damage parts such as a core or coil when raising the electromagnet.

(e) Core Disassembly and Assembly

When disassembling and re-assembling the upper core in order to perform actions such as vacuum duct replacement, do so following the procedure below.

- [1] Remove the terminal cover and disconnect the electrical wiring from the coil terminals. In addition, disconnect the connection terminal across the upper and lower coils.

- [2] Remove the water from the cooling water piping and then disconnect the rubber hose. In addition, disconnect the measurement instrument wiring for the temperature switch as well as the damping resistance wiring.
- [3] Install the suspension bolt on the upper area of the core and pull the wire rope using a crane.
- [4] Remove the support bolts.
- [5] Slowly raise the core upper area.
- [6] Place the lifted core on the established location. When lowering the core, be careful that there is no direct contact with parts such as the pole surface or coil.
- [7] To assemble the core, follow the above steps in the reverse order. During assembly, carefully clean the unit, making sure that mating surfaces, in particular, are free of foreign material and dust.
- [8] Position the reassembled core using the knock pin provided on the support and core mating surface.

(f) Coating

The electromagnet is coated as indicated below. In the unlikely event of coating damage, replace the coating once every two to three years.

- [1] Core proper : Munsell 2.5RP4/12 (Purple)
- [2] Stand : Munsell 5Y7/1 (Gray)

(g) Lubrication

Grease is applied to the bolt thread areas of the position adjusters prior to delivery. Apply grease to the thread areas once every two to three years after delivery. Similarly, apply grease to the core bottom sliding area and load-receiving bolt head sliding area.

(h) Appendices

- [1] Flow Gauge Operating Instruction Manual
- [2] Thermal switch, Contact Protection Box Catalogue

Table 2 Q2 Quadrupole Magnet System Specifications

No.	Item	Specifications	Remarks
1	System symbol	Q2	
2	Quantity	1	
3	Maximum magnetic field gradient	4.19 [T/m]	
4	Magnetic effective length	766 [mm]	
5	Effective magnetic field range	W; ± 400 [mm]	
6	Magnetic homogeneity	$\pm 0.1\%$	
7	Bore diameter	145 [mm]	

Table 3 Q2 Quadrupole Magnet Design Elements (Per Electromagnet)

No.	Item	Unit	Design Value	Remarks	
1	Core	Material	-	Soft magnetic iron	
		Bore diameter	mm	145	
		Magnetic pole length	mm	600	
2	Coil	Magnetomotive force	AT	144000	
		Coil unit count	-	4	
		Winding count	-	320	
		Conductor dimensions	mm	13.5×11.5- ϕ 6.3	
		Resistance	m Ω	119	at 45°C
		Maximum current	A	450	
3	Cooling	Cooling method	Water cooling, 16 systems, in parallel		
		Cooling water quantity	17.3 [l/min]	Coil only	
		Pressure loss	0.38 [MPa]		
4	Mass		10500 kg		

Appendix 1

Flow Gauge Operating Instruction Manual

■ Specifications

- ◇ Flow rate accuracy : $\pm 5\%$ at FS
- ◇ Operating maximum pressure : 0.75 MPa (G)
- ◇ Operating fluid temperature : Max 80°C
- ◇ Operating environment temperature : 0-60°C (non-condensing)
- ◇ Contact method : A contact
B contact
- ◇ Contact voltage resistance : AC500V, 1 minute
- ◇ Withstand voltage : AC1500V, 1 minute
- ◇ Contact open/close service life : 1 million times, minimum, with pure load resistance
- ◇ Contact accuracy : Within FS $\pm 10\%$
- ◇ Code length : 2m

Outside standard specifications:

AC/DC 100V	0.25A	20W	$\cos \phi=1$
AC/DC 100V	0.1A	20W	$\cos \phi=1$

⚠ Warning

- * Be careful not to exceed the rated pressure or temperature. Exceeding the rated values results in risk of tapered tube damage.
- * Be careful not to introduce overcurrent to the sensor. Overcurrent results in sensor malfunction. In addition, be careful of large external magnetic fields. Exposure to such fields causes malfunction.

■ Checking the Flow Rate and Contacts

- ◇ Checking the Flow Rate

A white line is provided on the indicator attached to the outside of the tapered tube. The scale mark that aligns with the white line indicates the present flow rate.

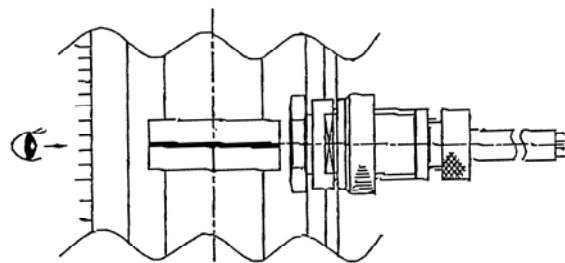

✧ Setting the Contacts

Tightening the switch nut slides the switch. Slide the pointer to the desired setting and turn the contact ON/OFF.

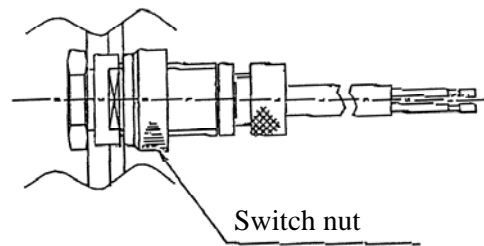

 **Caution**

■ **Structure and Disassembly/Assembly Standard**

✧ Structural Drawing

See the structural drawing.

✧ Disassembly/Assembly Standard

1. The FC-SD model consists of types with a sensor and without a sensor, and types with a support spring [18] installed and without a support spring installed (floating type).
2. First, remove the front frame [4]. The front frame [4] is installed with four screws. Loosen and remove each of these screws.
3. Next, remove the scale plate [8]. The scale plate [8] is installed with two M2 screws. Remove these screws.
4. If the FC-SD has a sensor, remove the “sensor unit.”
The “sensor unit” refers to the pointer [6] and sensor assembled with the sensor plate [15]. When handling the sensor, handle the assembled sensor unit as a whole. The sensor unit is removed by removing the four screws of the sensor plate [15].
5. If the unit does not have a sensor, remove the back plate [16].
6. Once the sensor unit has been removed from the unit with a sensor, and the back plate [16] has been removed from the unit without a sensor, the disassembly procedure is the same for both units.
7. Next, disassemble the main body.

Flange Type

With a flange type unit (FC-SD70F, FC-SD85F, FC-SD85LF or FC-SD130F), insert the case [3] into a vice and remove the fitting [1] using a hook wrench.

You can loosen and remove the screws by hooking the hook wrench into the four holes of the fitting [1] and bringing the wrench back toward the left. By doing so, the fitting on either the IN side or the OUT side is removed.

8. Next, remove the remaining fitting [1] using the same procedure. This time, the fitting [1] is removed along with the “tapered tube unit.”

- * If the unit has the support spring [18] installed, remove the support spring [18] at this time.

The support spring [18] consists of a spring and a backup ring that supports that spring. The exact same parts are used on both the IN side (flow introduction side) and the OUT side (flow discharge side), and are simply inserted in the tapered tube unit. During installation, therefore, insert the support spring into the tapered tube unit without differentiating between the IN side (flow introduction side) and OUT side (flow discharge side).

The tapered tube unit consists of a tapered tube [10], spring [11] (unless the unit type is a floating type), float [9], guide pole [12] and stoppers [13]. When these parts are assembled into a single unit, that unit is referred to as the “tapered tube unit.”

- * At this time, the indicator [7] is removed while inserted in the tapered tube unit. During removal, be careful not to damage the indicator [7].
- * When setting the case [3] in the vice, be careful not to damage the case [3].

With Rc Screws

9. When the fitting [1] consists of an Rc screw, set the hexagon area of either the IN-side or OUT-side fitting [1] in a vice, bring the wrench back toward the left to loosen and remove the screw.

10. Next, for the remaining fitting [1], set the case [3] in a vice, take hold of the hexagon area of the fitting [1] with a wrench and bring the wrench back toward the left and remove the fitting [1].

- * If the unit has the support spring [18] installed, remove the support spring [18] at this time.

The support spring [18] consists of a spring and a backup ring that supports that spring. The exact same parts are used on both the IN side (flow introduction side) and the OUT side (flow discharge side), and are simply inserted in the “tapered tube unit.” During installation, therefore, insert the support spring into the tapered tube unit without differentiating between the IN side (flow introduction side) and OUT side (flow discharge side).

The tapered tube unit consists of a tapered tube [10], spring [11] (unless the unit type is a floating type), float [9], guide pole [12] and stoppers [13]. When these parts are assembled into a single unit, that unit is referred to as the tapered tube unit.

- * At this time, the indicator [7] is removed while inserted in the tapered tube unit. During removal, be careful not to damage the indicator [7].
 - * When setting the case [3] in the vice, be careful not to damage the case [3].
11. Lastly, disassembly the tapered tube unit. The tapered tube unit is assembled inside the fitting [1]. Manually extract the tapered tube unit from the fitting [1].
 12. The tapered tube unit is tightened with double M3 or M5 nuts, depending on the model. Set the M3 or M5 socket wrench on the nuts at the ends of the tapered tube [10] one at a time and loosen the nuts toward the left to loosen and disconnect one end.
 13. Once the M3 or M5 nuts have been removed, gently remove the guide pole [12] that guides the float [9]. Next, remove both the IN-side and OUT-side stoppers [13] using a radio pliers.
 14. Lastly, remove the remaining spring [11] and float [9] from inside the tapered tube [10]. The unit is now disassembled.
 15. To assemble the unit, follow the procedure for disassembly in the reverse order. First assemble the tapered tube unit.
 16. Next, install the fitting [1] so that the tapered tube unit can be inserted. At this time, tighten the fitting [1] slowly and carefully to ensure that the O-ring housed in the groove of the fitting [1] does not get damaged.

With FC-SD65

1. Be sure to review structural drawings.
2. First, remove the front frame [4]. The front frame [4] is installed with four hexagon socket head bolts. Loosen and remove each of these bolts.
3. If the unit has a sensor, remove the “sensor unit.”
The sensor unit refers to the pointer [6] and sensor assembled in the sensor plate [15]. When handling the sensor, handle the assembled sensor unit as a whole.
The sensor unit is removed by removing the four screws of the sensor plate [15].
4. If the unit does not have a sensor, remove the back plate [16].
5. After the sensor unit or back plate [16] has been removed, disassemble the main unit.
 - Disassembling the Main Unit

6. Eight screws are installed on the back of the case [3]. Loosen these eight screws and remove the case [3] from the fitting [1].
7. Once the case [3] has been removed, pull the fitting [1] vertically or horizontally in both directions to separate the tapered tube unit and the fitting [1].
 - Precautionary note
 - * At this time, pulling the fitting [1] with excessive force may damage the internal O-ring. Be careful not to use too much force.
 - * The tapered tube unit is removed with the indicator [7] inserted inside the unit. During removal, be careful not to damage the indicator [7].
8. Next, disassemble the tapered tube unit.
The tapered tube unit consists of a tapered tube [10], spring [11] (unless the unit type is a floating type), float [9], guide pole [12] and stoppers [13]. When these parts are assembled into a single unit, that unit is referred to as the “tapered tube unit.”
9. The guide pole [12] is tightened with double M3 nuts. Set the M3 socket wrench on the first of the double nuts and remove the nuts starting from the first nut.
10. Once the M3 nuts have been removed, gently remove the guide pole [12] that guides the float [9].
11. Lastly, remove the remaining spring [11] and float [9] from inside the tapered tube [10]. The unit is now disassembled.
12. To assemble the unit, follow the procedure for disassembly in the reverse order. First assemble the tapered tube unit.
13. Next, assemble the tapered tube unit in the fitting [1], install the case [3] and float frame [4], and lastly install the sensor unit.
 - Precautionary notes
 - * When assembling the tapered tube unit to the fitting [1], be careful not to damage the O-ring installed in the fitting [1].
 - * When installing the sensor unit, be careful that the position of the pointer does not shift.

Drip-Proof Type

1. First, remove the terminal cover [1].
The terminal cover is installed with four screws. Remove the four screws.
2. Next, remove the terminal panel. The terminal panel is installed with two M4 screws. Rotate the screwdriver back toward the left and loosen and remove the screws.

3. Lastly, remove the drip-proof case [2]. The unit is now disassembled.
The drip-proof case is installed with four M3 screws. Loosen the screws and remove the case.
4. To assemble the unit, follow the disassembly procedure in the reverse order.
First install the drip-proof case and then the terminal panel. At this time, install the sensor wiring.

With K1 Specifications

Disassembly Procedure for Adjusting the Lead Switch

1. Remove the two hexagon socket head bolts that secure the cover case diagonally.

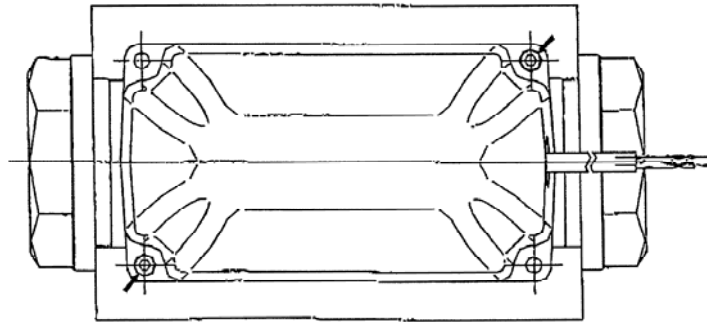

2. Push the cable inside the cover case and, while maintaining enough room, remove the case.

Note 1: Be careful not to pull the cable.

Note 2: Be careful not to loosen the grommet.

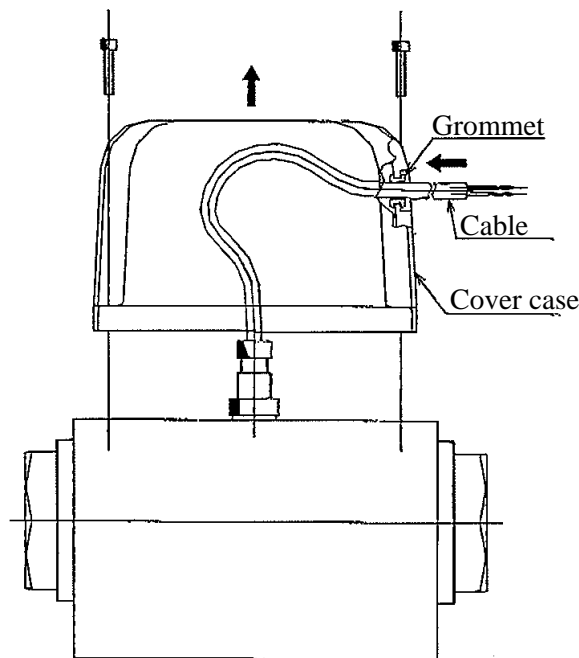

3. Remove the two screws that secure the cover plate diagonally.

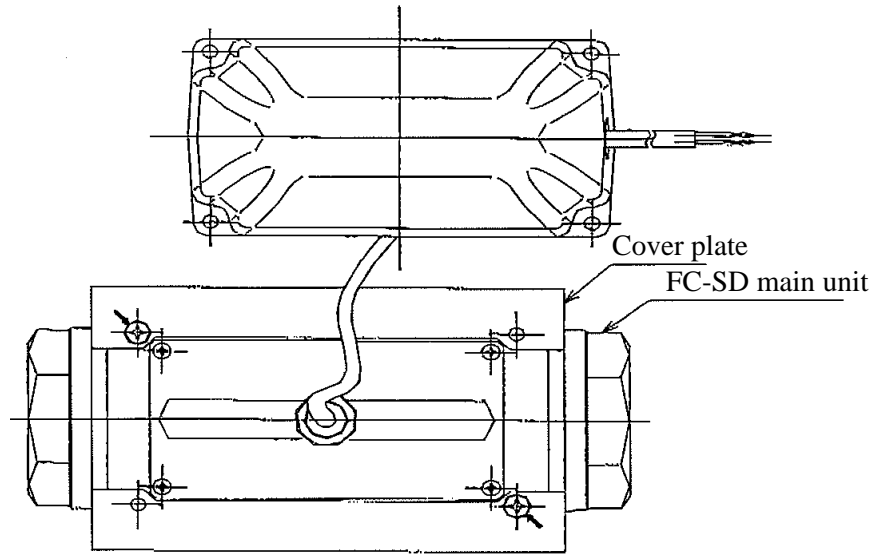

4. Slide and remove the cover plate from the main unit.

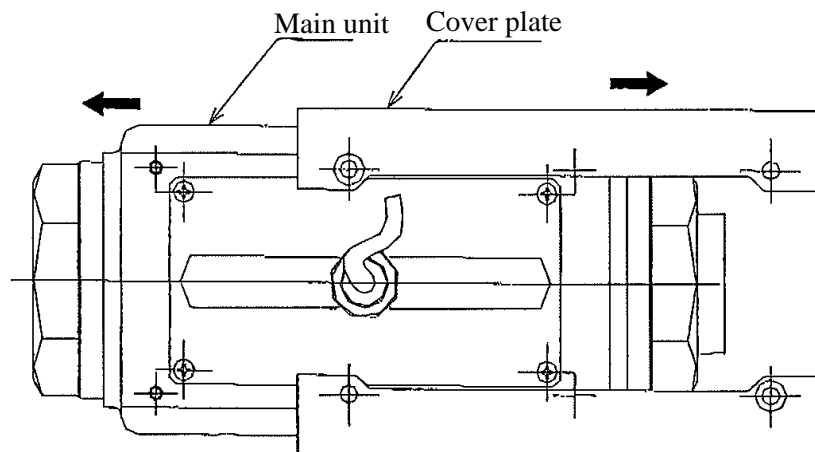

! Caution

■ FC-SD Series Maintenance and Inspection

1. With the flow rate indicator type, if the indicator [7] does not reflect flow rate increases or decreases, either the float [9] inside the tapered tube is not following the flow rate or contaminants such as metallic dust are clogging the float [9]. Remove the float plate [5] and try to move the indicator [7]. You will know if the indicator is not readily following the float [9] in the tapered tube by feel. In this case, the float [9] may not be able to move due to the clogging of foreign material such as metallic

dust. Disassemble the unit while referring to the disassembly/assembly standard of the previous section and identify the cause.

2. When assembling the unit, be careful that the magnetic fields of the float [9] and indicator [7] are not installed in reverse. The float and indicator should always be pulling at each other.
3. Introducing a current higher than the rated level may result in malfunction, necessitating switch replacement. Be careful of the current level.
4. Overhaul the unit periodically.
5. The sensor setting is variable. The setting can be changed onsite.
6. When you wish to perform steam sterilization, turn off the sensor power.

* The flow gauge proper is not under warranty when disassembled by your company.

Appendix 2

Thermal swith, Contact Protection Box Catalogue