

Q2Q3D Specifications, Requirements and Scope

Paul Brindza

Q2Q3D Outline

- Q2Q3 and Dipole Specifications
- Q2Q3D Status
- Q2Q3 and Dipole Contracts
- Scope of Work JLAB
- Scope of Work SigmaPhi
- Contract Reviews
- Contract Documentation

SHMS 11 GeV/c Spectrometer Hall C- June 2016

New companion to the 25 Year old HMS 7.4 GeV/c spectrometer

- 11 GeV/c
- 5×10^{-4} dP/P resolution
- 4 mStr. Acceptance
- 5.5 to 40 degrees
- Momentum bite 20%



SHMS Spectrometer- June 2016

detectors and magnet yokes



SHMS Magnets and Systems

- Cryo-Control Reservoirs
- Cryogenics Infrastructure

- Cryo-Control Reservoirs
- Cryogenics Infrastructure

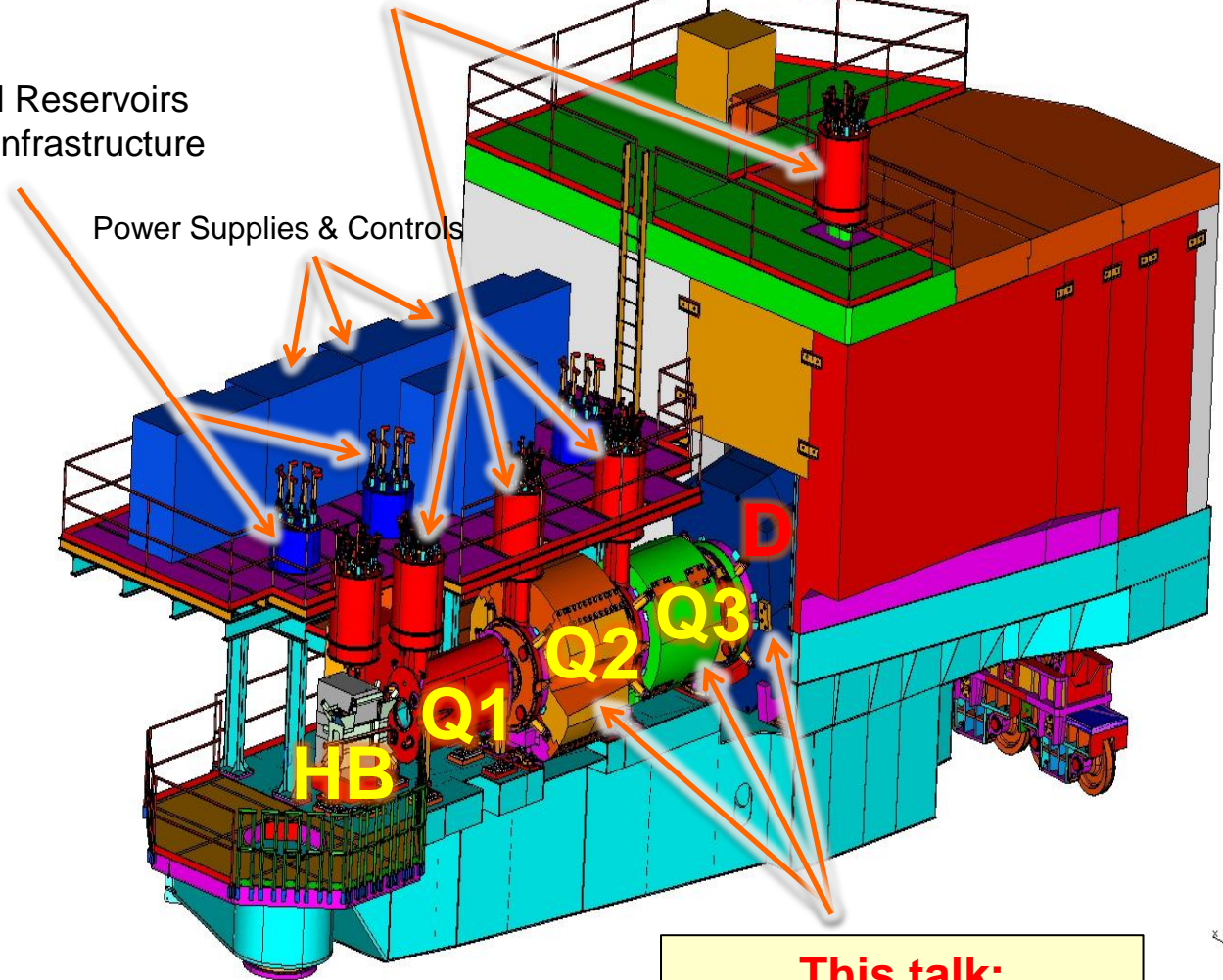

1×10^{-3} dP/P Resolution
4 mSr Acceptance
1 to 11 GeV/c

Warm Yoke steel
Magnet
Supports

**This talk:
Q2, Q3 & Dipole
Vendor = Sigma Phi**



SHMS Dipole/Q2/Q3

DIPOLE:

- 3.86 Tesla Cosine(θ) dipole
- Bath Cooled 1.2 Atm, 4.42K
- 60 cm warm bore
- 2.85 m EFL
- 11.2 Tm Integral B.dL
- 17 MJ stored Energy
- 11 GeV/c
- Warm Iron Yoke: 126 Tons

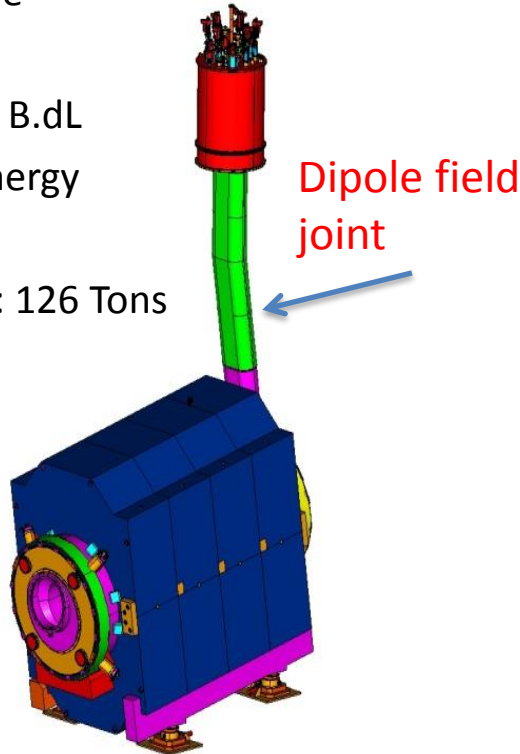

Q2 (shown):

- 11.8 T/m $\cos(2\theta)$ Quad
- Bath Cooled
- 1.2 Atm., 4.42K
- 60 cm. warm bore
- 1.64 m EFL
- 7.6 MJ stored Energy
- Warm Iron Yoke: 72 Tons

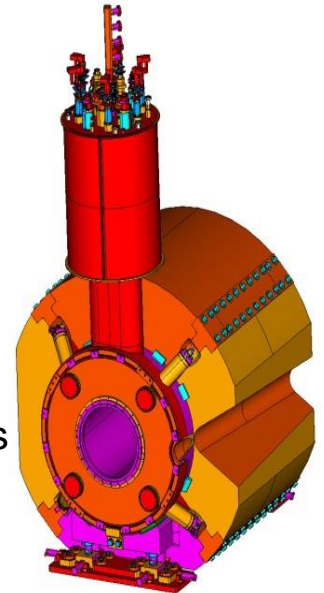

Q3:

- Identical to Q2 but runs at 7.9 T/m
- Warm Iron Yoke: 18 Tons
- Both use same conductor as dipole (Cu + SSC outer)

SHMS Dipole Q2/Q3 Specifications @ 11 GeV/c

| | Q2 | Q3 | Dipole |
|--|-------------------------------------|-------------------------------------|-------------------------------------|
| Type | Cos 2 θ | Cos 2 θ | Cos θ |
| Field/grad | 11.8 T/M | 7.9 T/M | 3.9 T |
| EFL | 1.64 M | 1.64 M | 2.85 M |
| Energy | 7.6 MJ | 3.5 MJ | 17 MJ |
| Inductance | 1.14 H | 1.14 H | 2.86 H |
| Current | 3660 A | 2480 A | 3450 A |
| NI | 6.3 MAT | 4.2 MAT | 4.2 MAT |
| aperture | 60 cm Φ | 60 cm Φ | 60 cm Φ |
| Dump Volts | 270 V | 180 V | 240 V |
| Dump R | 0.075 Ω (50 msec delay) | 0.075 Ω (50 msec delay) | 0.075 Ω (50 msec delay) |
| Conductor Soldered cable in channel | 0.3x1.9 cm ² + SSC outer | 0.3x1.9 cm ² + SSC outer | 0.3x1.9 cm ² + SSC outer |
| AHS Temp | 45 K (1.02E8 miits) | 34 K (4.8 E7 miits) | 70 K (2.3 E8 miits) |

SHMS Dipole and Quad Magnet Coils

SHMS Quad 2/3

- 8 Layer, 4 Dbl. Pancake
- 2 sector Cos. 2 Theta coil
- Constant Perimeter ends
- 427 Turns/pole

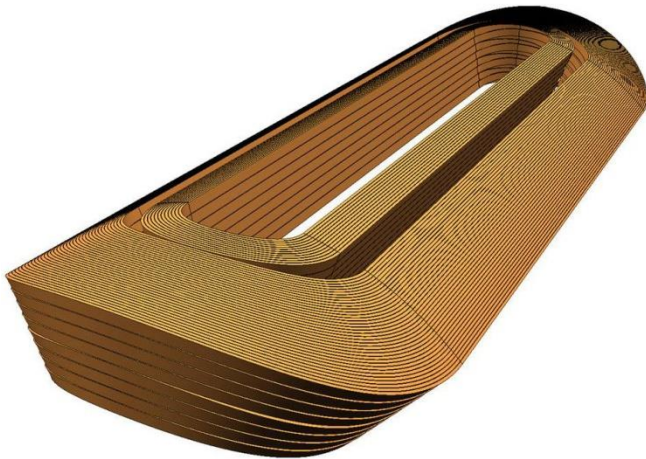

SHMS Dipole

- 6 Layer, 3 Dbl. Pancake
- 2 sector Cos. Theta coil
- Constant Perimeter ends
- 606 Turns/pole



Q2Q3D Interface Specifications

- JLAB Specified and provided the interface for:
 - Cryogenics- Cryo Control Reservoir
 - DC Power Supply- Danfysik (6 V, 4000 Amps)
 - QD/QP- DF quench detector and energy dump
 - Controls – Hall C PLC
 - External Instrumentation- Pressure, LL, Vac, lead flow
 - Internal sensors- detailed spec and wiring in Tech Spec
 - Magnet operating conditions- 4.4 K 1.2 Bar

ASME, Pressure, Leak, VCL and Cryo Spec's

- ASME BPV Section VIII design, fab, test, material certs, welders certs and documentation required- No U Stamp
- Pressure Max HE 75 PSIG, Max LN2 75 PSIG
- Pressure test – 90 PSIG He & LN2
- Leak Test Spec- none at 1×10^{-9} Atm cc/sec
- Cryogenic $Q_{He} < 40$ W, $Q_{N2} < 100$ W
- VCL 5 KA burnout resistant (1.8 LL/Hr/KA, 80mV)
- VCL TESTED conduction limit ~ 3700 A $> Q2Q3D I_{op}$

Hall C SHMS Magnets a Year Ago – June 2015



HB @ JLab
(MSU/FRIB)

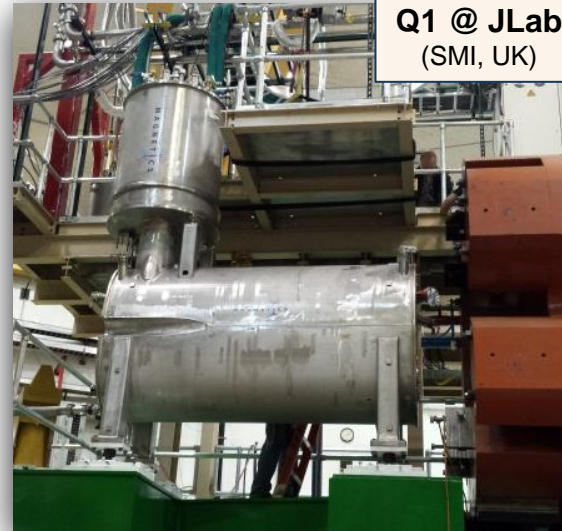

Q1 @ JLab
(SMI, UK)



Dipole Trial Collaring
(Sigma Phi, France)



Q2 splicing
(Sigma Phi, France)

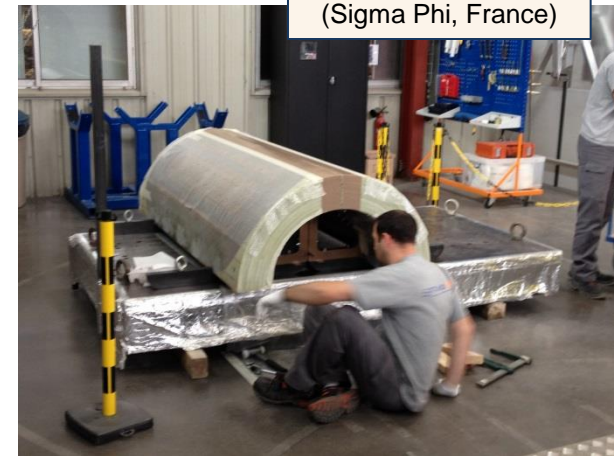

Q3 coil assembly
(Sigma Phi, France)

SHMS Q1 and HB Status



- **Q1:**

- Installed on SHMS
- Cooled down
- Power test to 3000 Amps or 110% of operational current
- Accepted 2015

- **HB:**

- Installed on SHMS
- Cooled down
- Power test to 4000 Amps or 102% of operational current
- Accepted 2016

Dipole , Q2 & Q3 April 2016



Q3 & Dipole June 2016

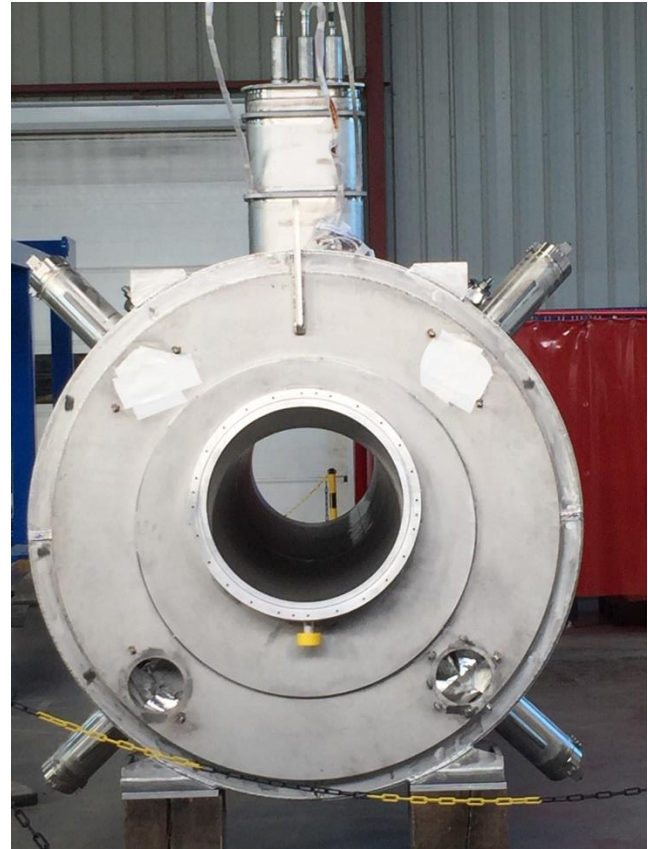

Q2 July & August 2016



Q2 has landed! Norfolk VA 10/5/16



Q2 in JLAB Hall C 10/8/16



Q2 Mounted on the SHMS 10/9/16



SHMS October 11, 2016

Q2 Installed with yoke

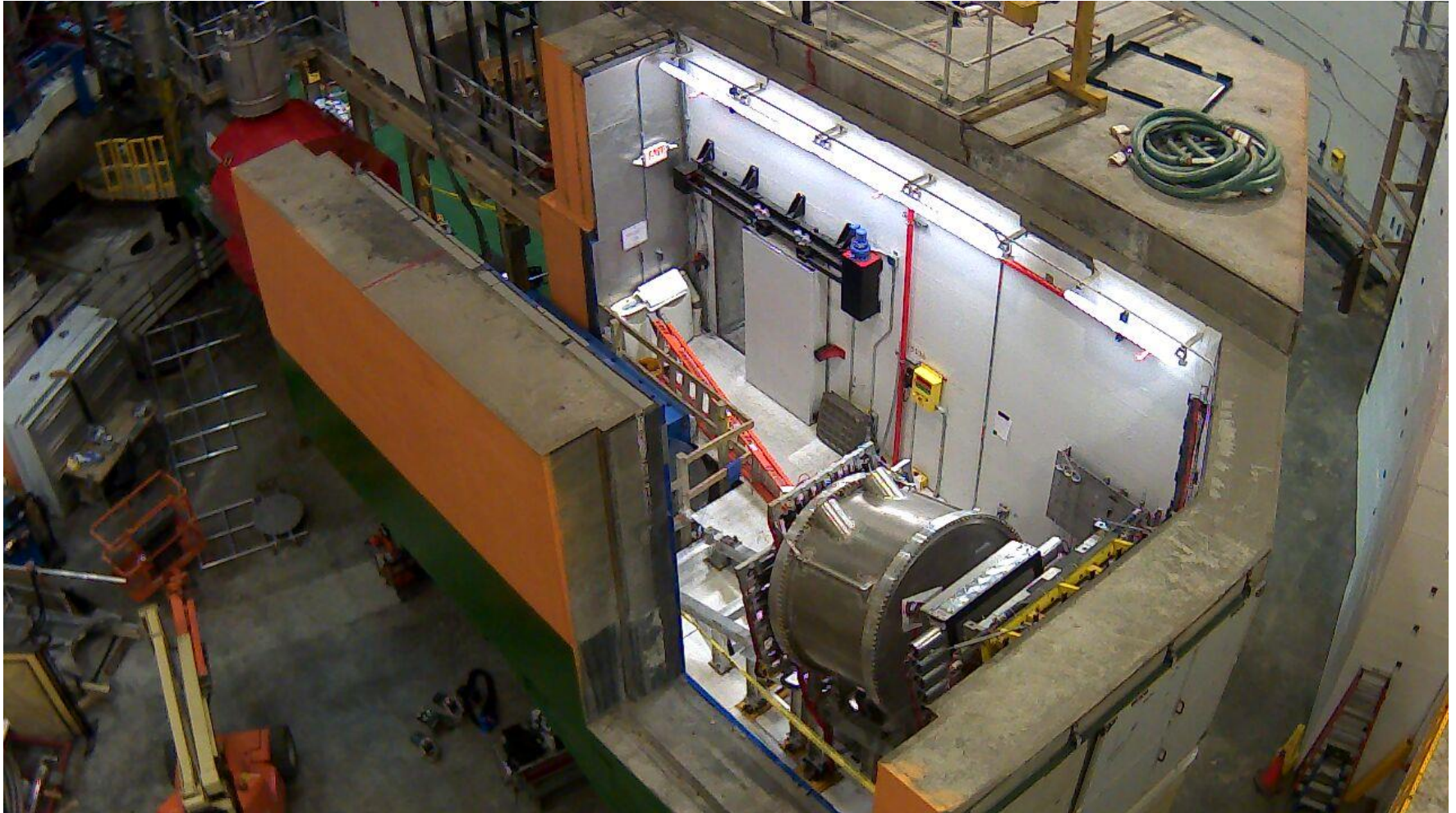

Q2Q3Dipole Status

- Q2 is in JLAB Hall C installed on SHMS and under vacuum- Yoke and Platform assembly underway
- Dipole is in Antwerp waiting for its ship- ETA Virginia is 10/28/16
- Q3 is complete, leak tested and final welding underway – shipping date is 10/31/16
- Documentation
 - FDR Drawings, analysis, reports- Complete
 - Dipole manufacturing Doc. ~ 90 % complete
 - Q2Q3 manufacturing Doc.~ 80 % complete

Q2Q3 and Dipole Contracts

- Two Fixed price Design Build Contracts placed with SigmaPhi as a result of a competitive “Best Value” award process- world bidders list- Buy America Act
- Bid documents included a JLAB Reference Conceptual Design(RCD) for both magnets including CAD models, TOSCA models, FEA, models, drawings, reports, test results
- Dipole Contract awarded Aug 2010
- Q2Q3 Contract awarded Oct 2010

Q2Q3Dipole Contracts

- Q2Q3D were 4 year contracts now about 6 years
- Q2Q3D fixed price contracts ~ 20% delta
 - Extra scope items- consolidation and tests
 - Productivity investments- extra tooling and shifts
 - Storage of JLAB excess conductor and tooling
 - Negotiated costs for extra work and problems

SHMS SC Magnet System Plan

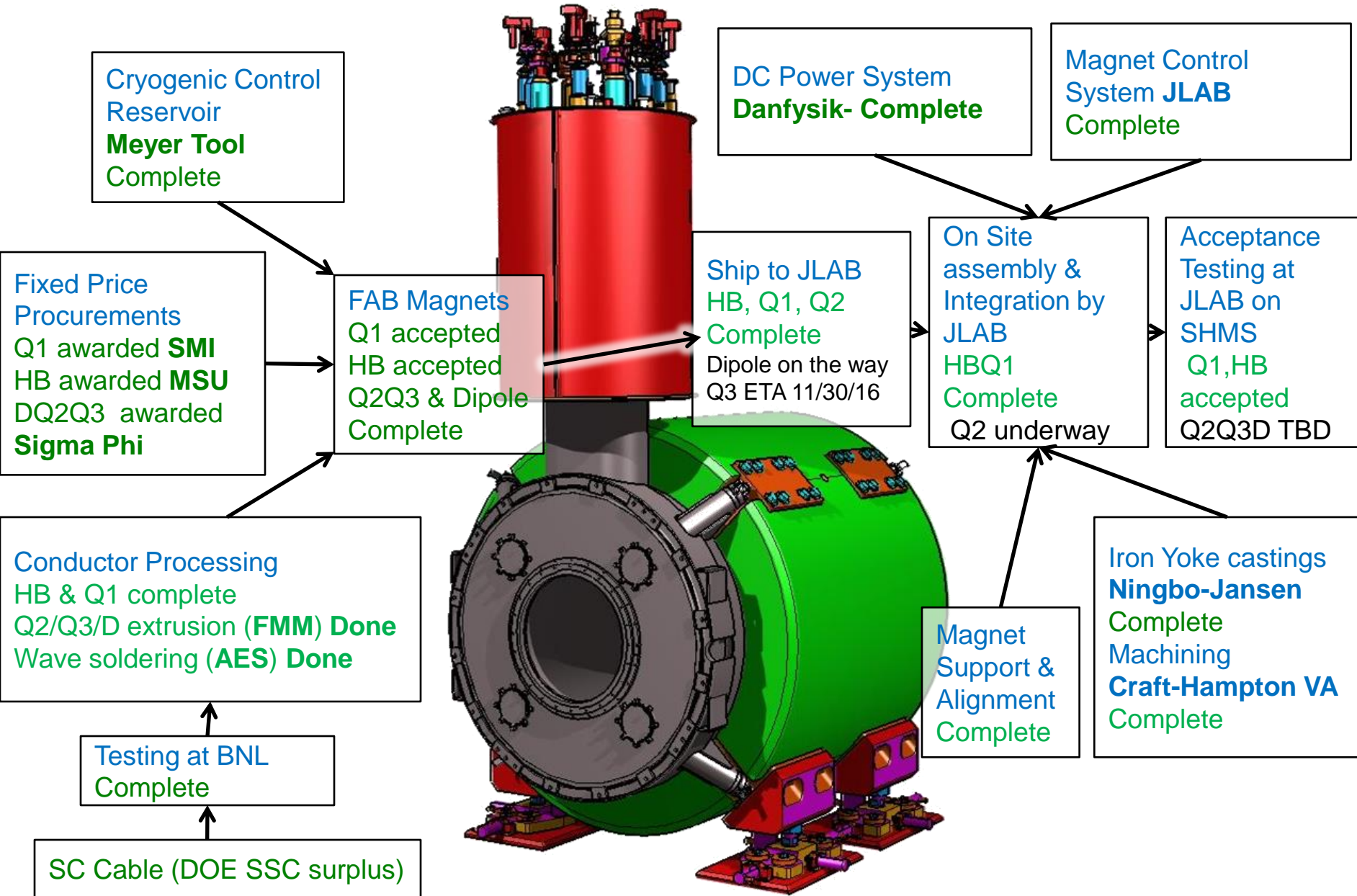

Scope of Work - JLAB

- RCD provided by JLAB
- Conductor
 - Superconductor(surplus SSC outer 32 strand cable)
 - Copper Stabilizer(copper channel extrusion - FreeportMcMoran)
 - Soldering(AES, Allentown PA)
- Cryo-Control Reservoir(CCR)- Meyer Tool & Mfg.
- Burnout Resistant Vapor Cooled Leads, Mfg. & Testing (AMI)
- DC Power Supply (DCPSU)- Danfysik
- Quench protection and Detection- Danfysik
- PLC controls, instrumentation read out, logging-JLAB Hall C
- Warm Yoke- Ningbao-Jensen & Craft Machine
- All on site installation and assembly except soldering dipole SC bus-Hall C
- All on site services for Acceptance Testing (labor, cryogenics, AC power)
- Plus all the free advice the contractor can stand!

Scope of Work - SigmaPhi

- Q2Q3 and Dipole Design and Analysis thru manufacturing drawings including ASME
- Design & build all manufacturing tooling
- Design all manufacturing processes
- Design and perform all QA, QC, Inspections and Tests
- Preliminary, Intermediate and Final Design reviews
- Q2Q3D Documentation
- Attend and present at ERR review (today)
- Integrate JLAB items (SC, CCR, VCL's) into Q2Q3D
- Attend Magnet Arrival Tests and Acceptance tests

Scope of Work SigmaPhi II

- Manufacture Q2Q3D SC magnets
 - Consolidate conductor (contract mod)
 - Wind coils
 - Vacuum impregnate coils
 - Assemble coils into cold masses
 - Collar coils
 - Magnet instrumentation(Volt Taps, LHE&LN2 Temp. sensors, strain gauges)
 - ASME Code test and documentation- Apave
 - Fabricate cryostats- SDMS
 - Final magnet assembly
 - Pack and ship to JLAB Hall C

Summary

- Fixed price contracts for Q2Q3 and Dipole have born fruit!
- Magnet installation has begun for Q2
- Dipole is on its way and Q3 is ready to ship
- Q2 Cool Down begins in ~ four weeks
- Q2 Low Power Testing begins in ~ 6 weeks
- Q3 Testing Jan 2017
- Dipole testing Feb 2017

Appendix VCL test results

PIX of Burnout proof VCL's

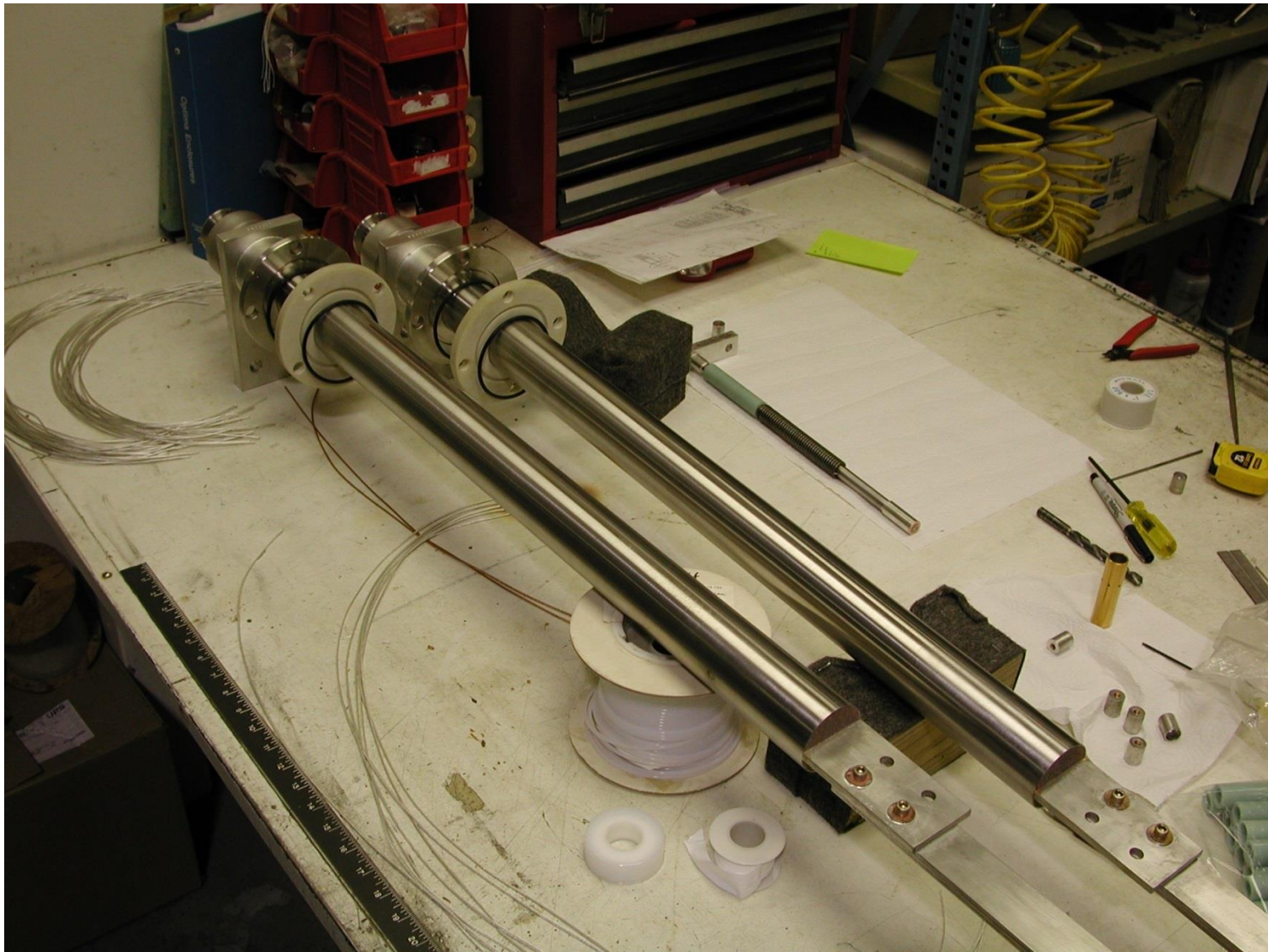

Development of Burnout Proof Current Leads for SHMS Magnets

- AMI/JLAB 5000 AMP burnout proof re-optimized vapor cooled current lead (1.63 L/Hr/KA)
- 5 KA lead pair designed, built and tested by AMI
- 5000 A DC No Cooling for 11.3 minutes **Safe**
- 3700 A DC No Cooling **Safe forever**
- 33 minute (2.5 A/sec) slow dump no cooling safe
- We required a safe 15 Minute slow dump non cooled discharge!

No burnout VCL 5 KA no coolant 11 min. test results

Figure 7
Tempertaure Profile - 5000 Amp Current Lead

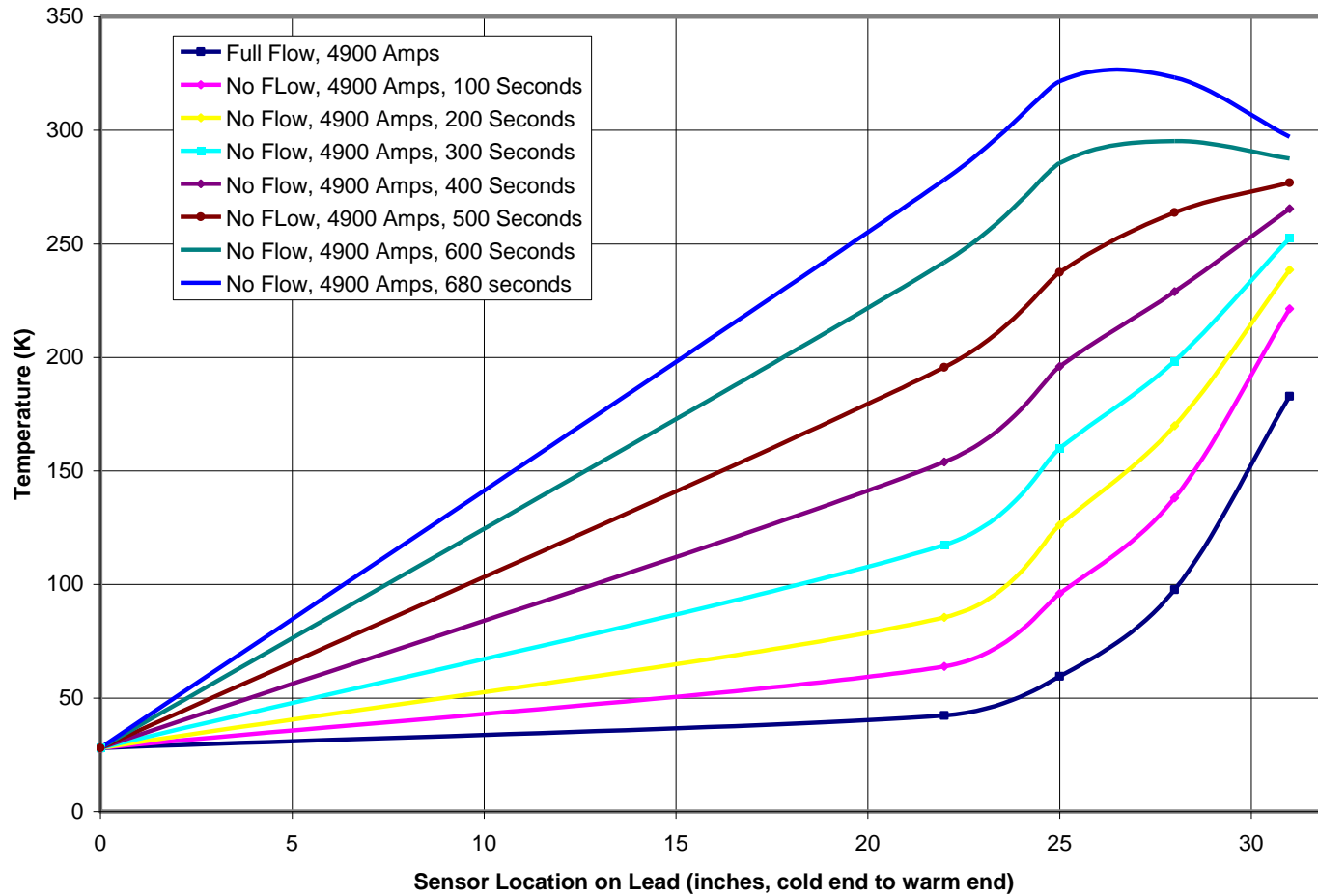

No burnout VCL discharge test results

Figure 9
Temperature Profiles vs. Time for Decreasing Current

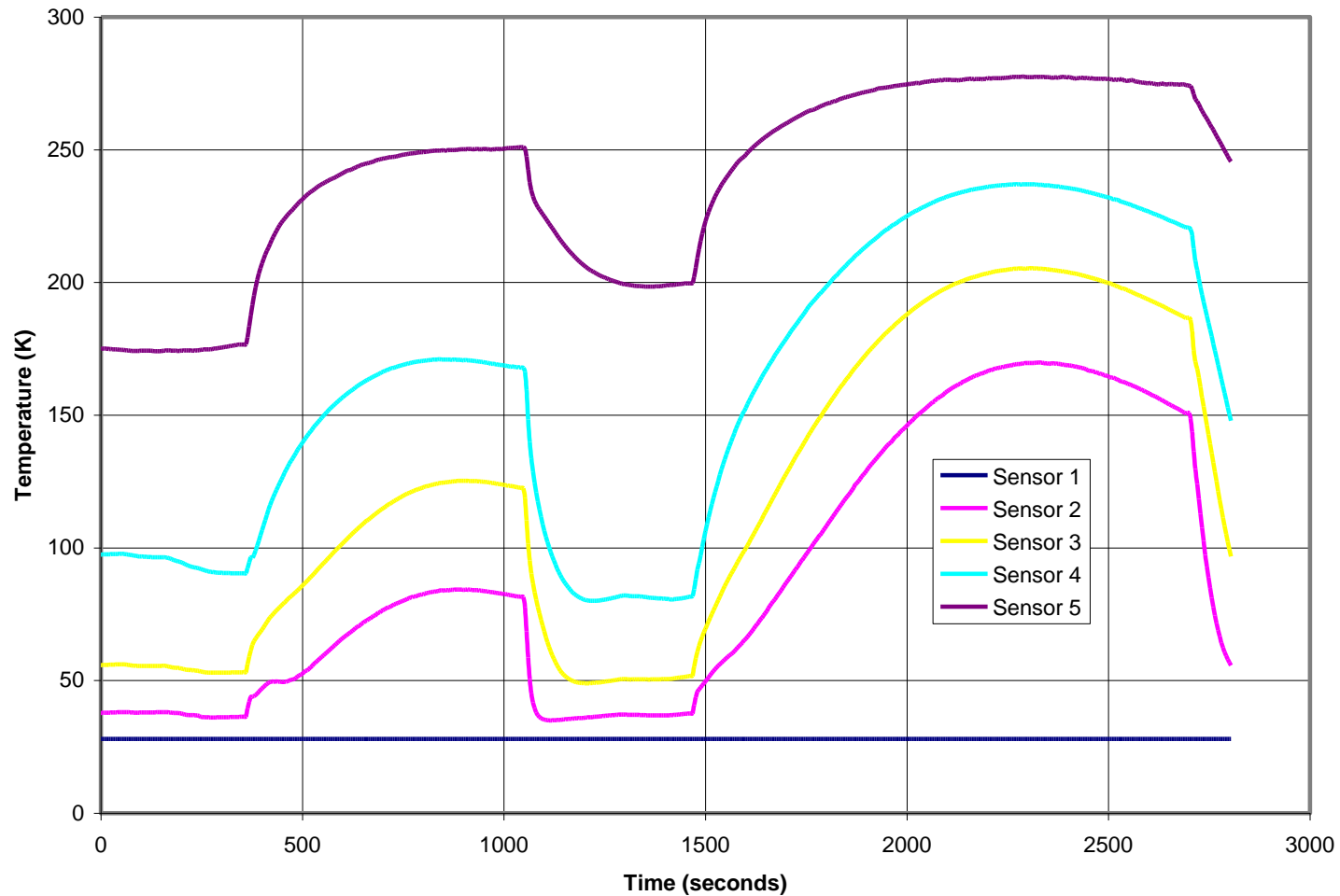

Appendix 2 SSC Cable tests

SSC Outer Cable Tests

- 12 samples of SSC outer cable tested at BNL
- Test Conditions ~ SHMS Magnets
- Field Range B (6T, 7T, 8T)
- Current $0 < I < 11,000$
- Tests at 4.2 K
- Results compare favorably to nominal short sample curve $I_c = 31532(1 - B/15)^{2.315}$ L. Dresner
- Typical I_c twice (or thrice) I_0 at constant B

SSC Outer Cable Measurements at 4.2 K

Ic measurements at 6T,7T and 8T

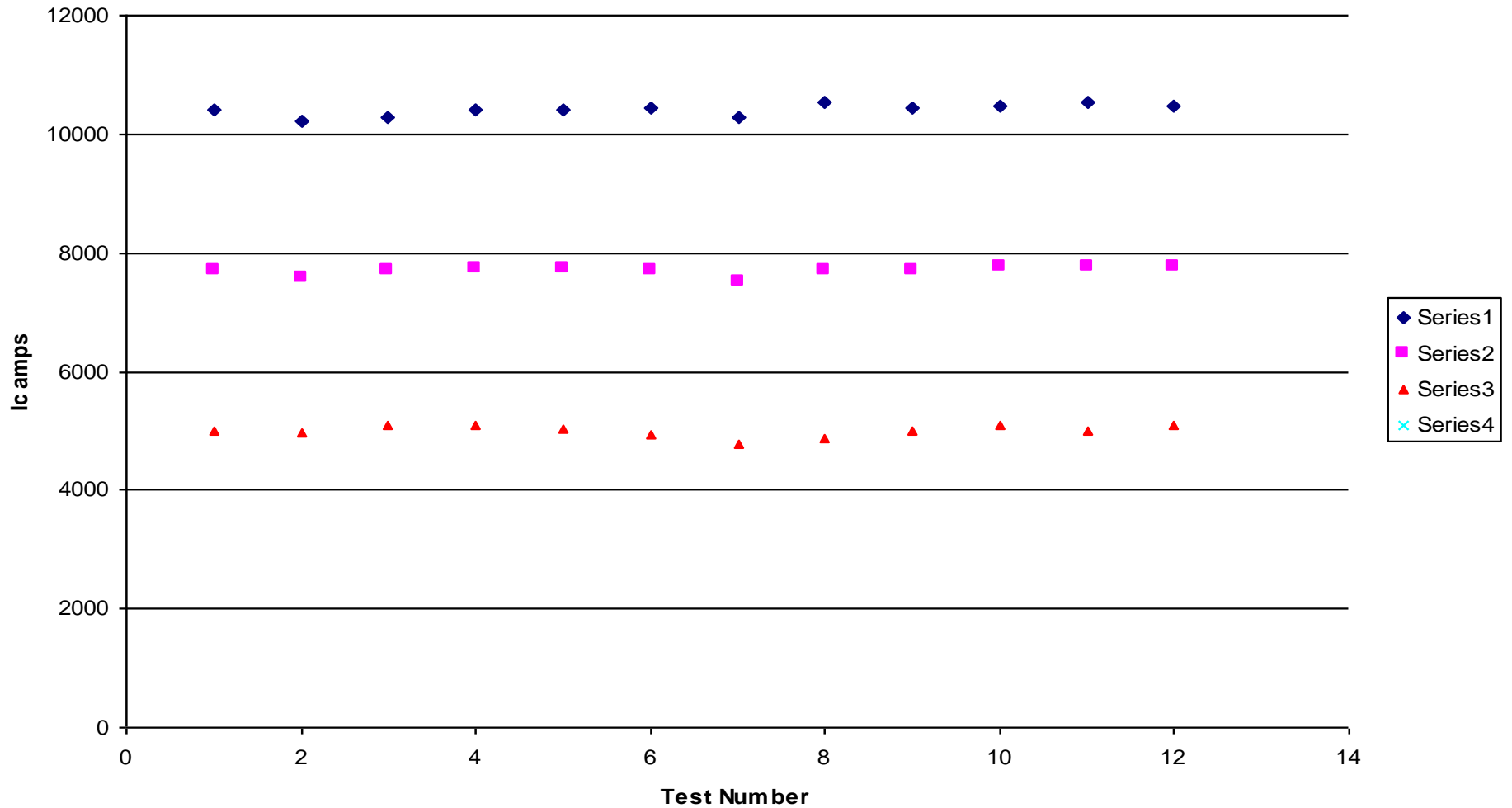

Cable Tests, Nominal SSC Outer Short Sample Curve & SHMS Dipole Peak Field Load line

Ic, Dipole Peak Field Load Line and Average of measurements

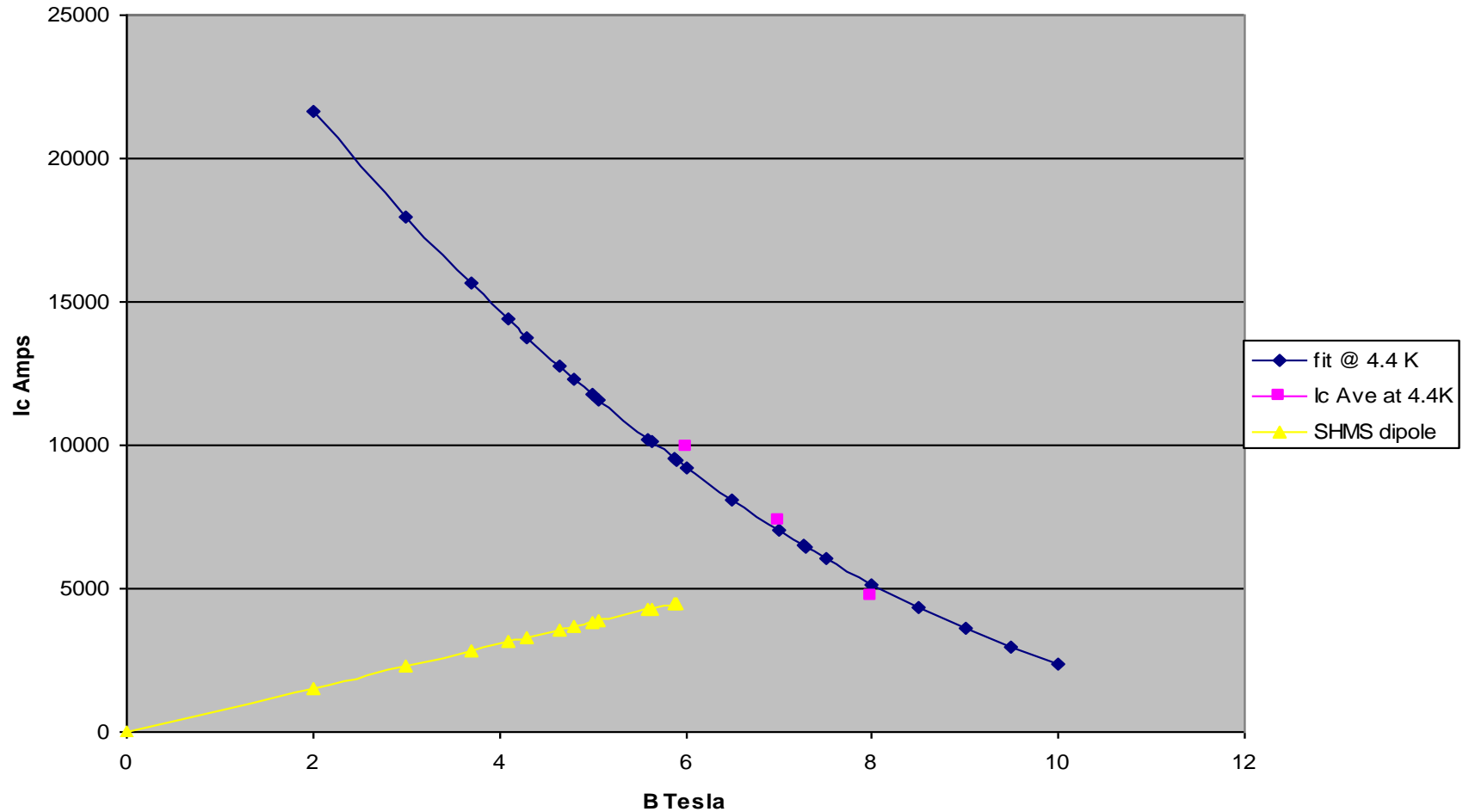

SHMS Dipole and Q23 temp margins

SHMS Dipole and Quad magnets stability and load lines

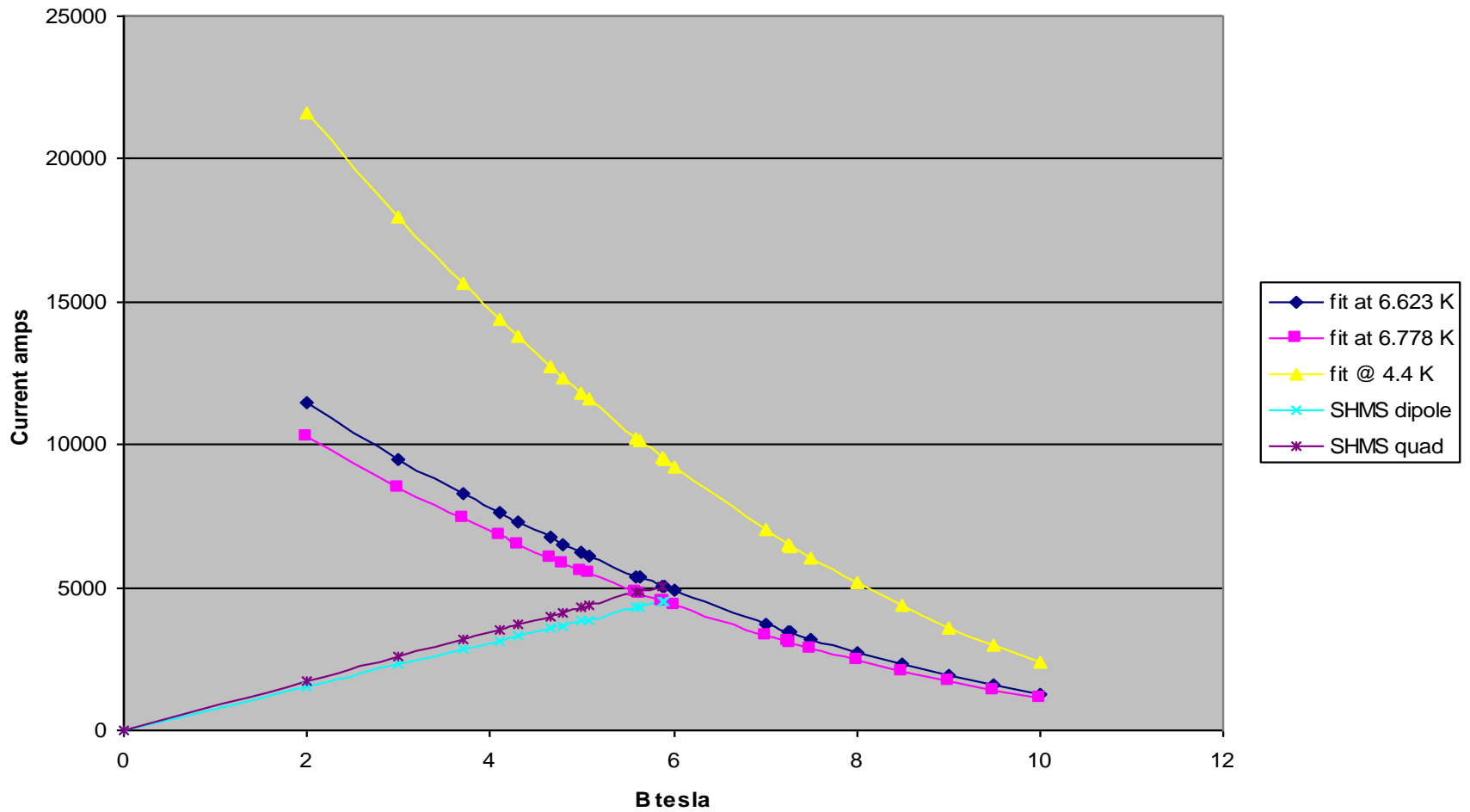

SHMS Q1' and HB Temp margins

Temp Margin for HB and Q1

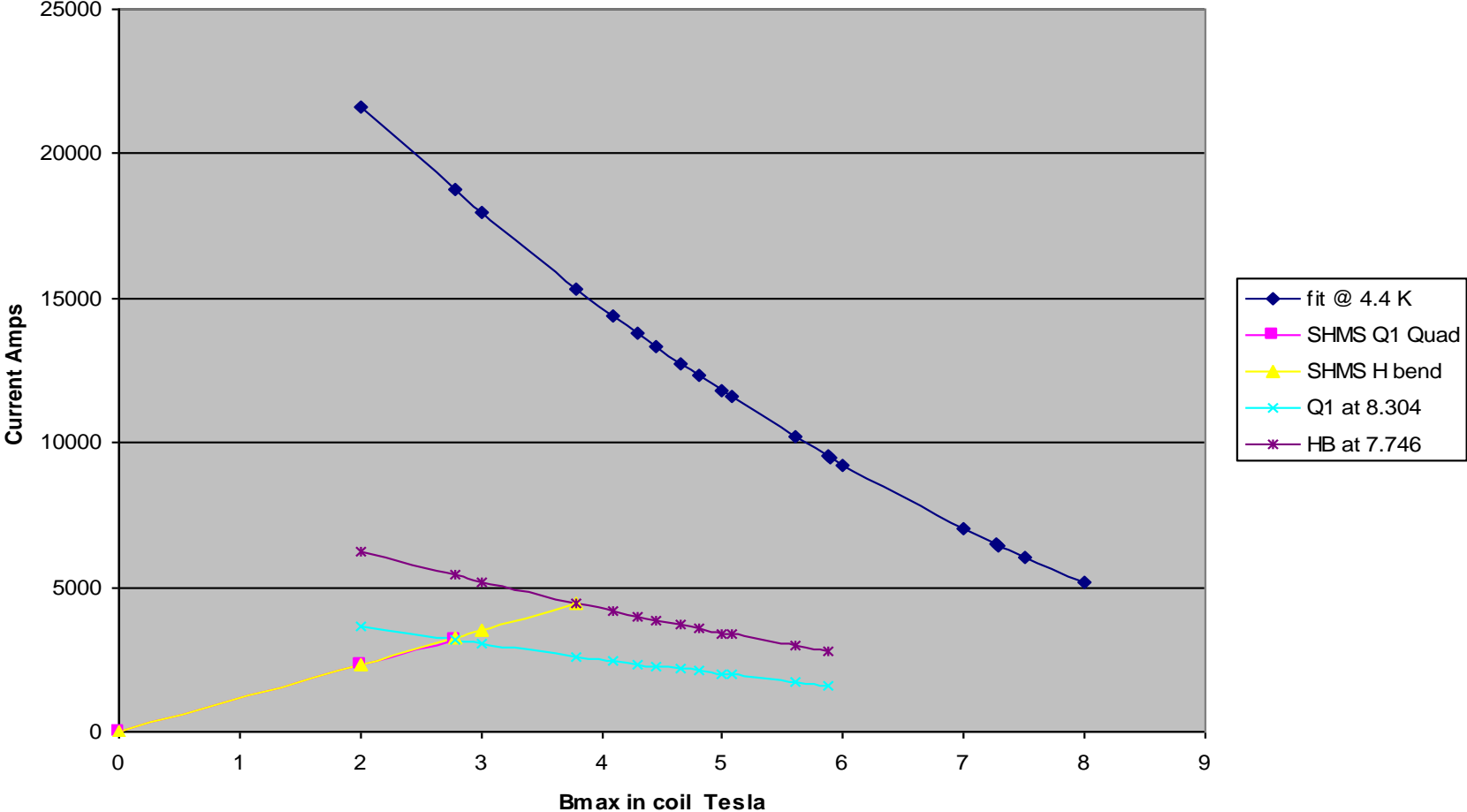

SHMS Operating Margins on Peak Field Load Line

| | Temp K | Current A | Ratio Ic/Io | Field T | Energy J/M |
|-----|-----------|--------------|----------------|------------|---------------|
| HB | 3.31 | 3408 | (1.77) | 2.91 | 0.088 |
| Q1' | 3.86 | 4659 | (1.46) | 3.92 | 0.213 |
| Q23 | 2.18 | 1217 | (1.24) | 1.43 | 0.480 |
| Dip | 2.34 | 1552 | (1.35) | 1.68 | 0.528 |