

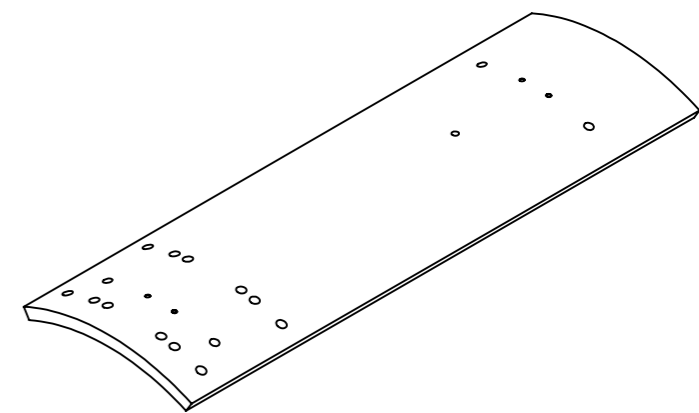

**VALIDATED ONLY FOR
MATERIAL PURCHASING**
DIMENSIONS
NOT VALIDATED
FOR PARTS
MANUFACTURING



MACHINING FOLLOWING CAO FILE

 ZI du prat Rue des frères Mongolfier F-56000 Vannes Tel(33) 02.97.01.08.80 Fax (33)02.97.01.08.81 EMAIL Contact@sigmaphi.fr	Name	Date
	Drawing	M.Delbecq
	Checked	
	Approved	
	MATERIAL:	Inox/Stainless steel 304L
	Trait.:	
	Roughness :	
	Tol Gen	+/-0.2
	Supplier:	
	Weight:	41.97 Kg
		ERREUR!:SW_Mas/Vo
		File name:317111-JLA-0200-102
DWG NO.	--317111-JLA-0200-102	
	Rev:	A
This drawing may not be used without special licence or authorisation express (Law of the 11 march 1957)		
	 A3	SCALE:1:10 SHEET 1 OF 1