

A 57 < B B ; : C @ C K B ; 7 " 5 " C " : @

**VALIDATED ONLY FOR  
MATERIAL PURCHASING**  
**DIMENSIONS**  
**NOT VALIDATED**  
**FOR PARTS**  
**MANUFACTURING**

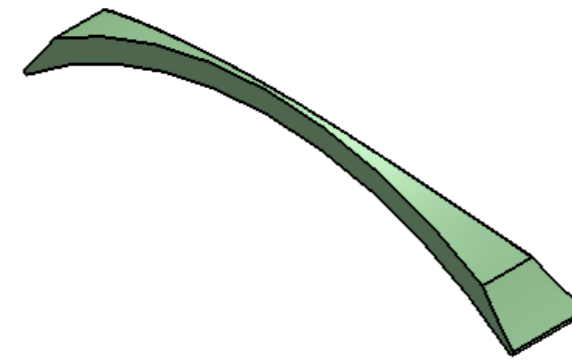

8-A 5L 9LD97 H98. % ( a a  
fXYHU ; ) Z \* - L  
fU Yfg 5 \* - Z ' L

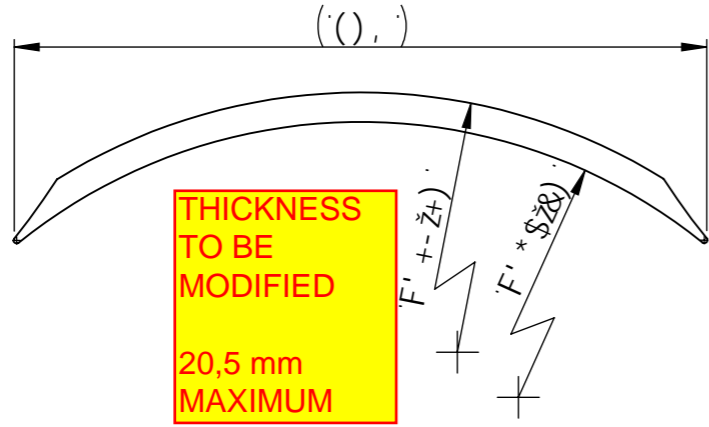
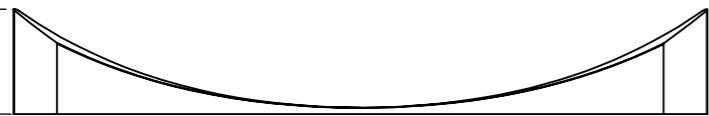

	BUa Y	8UY
	8fuk b[ A "8Y VYWe	&\$# \$ #&\$%&
7\YWLX		
5ddfcj YX	<b>G11 (EP 11)</b>	
A 5HF-5@		
HUjt.		
Fci [ \bygg.		
H: ; Yb	-\$"&	
G dd]Yf.		
K YI \b	\$"(- '?[	
: ]Y bUa Y.' %+%000 >@5!\$&\$\$, \$&		
8K ; 'BC"		FYj .
' %+%000 >@!& \$&		<b>B1</b>
V@/i/a q * A e0A[ o0^A * aA aq * A) ^&AaX) &A / a0 c0] i0 a00 } A 0] : ^.. See A-40/AF A e00/ J I D	5'	G7.5 (0.%)
		G<99H% C : %