

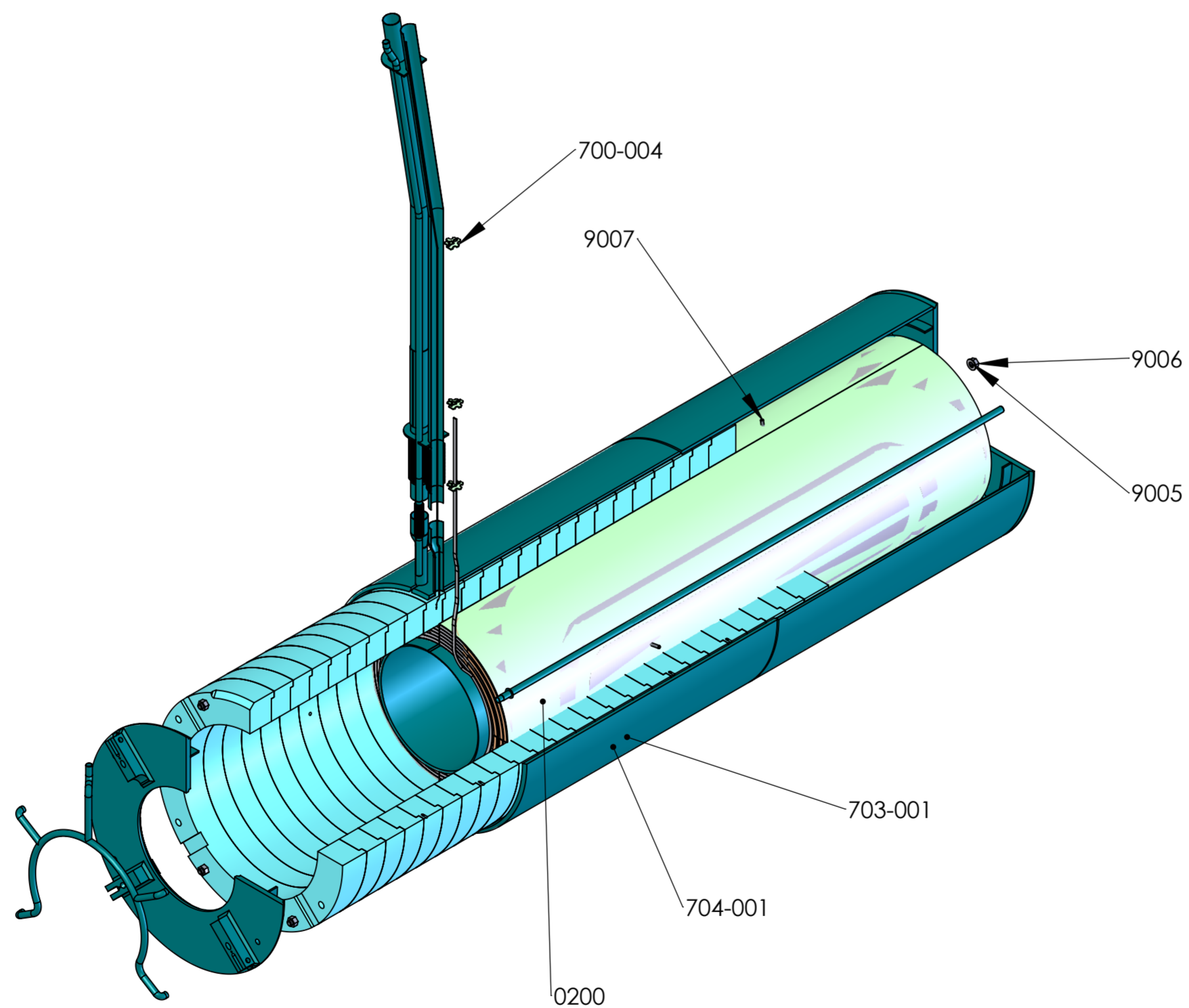

REP	REFERENCE	DESIGNATION	coupe/Quantité	REV	MATERIAL	SUPPLIER	MASS (Kg)
703-001	317111-JLA-703-001	He VESSEL	1	G	See assembly		3911.99
704-001	317111-JLA-704-001	Force rings	1	E	See assembly		5920.59
0200	317111-JLA-0200-pour-fabrication	Coil	1	F	-		5824.02
9005	Rondelle Ø 30 M inox304L	NVI9000	1		Matériau <non spécifié>		8.48
9006	Ecrou H M 30 Inox 304L	NVI9000	1		Inox/Stainless steel 304L		0.23
9007	16x80	Tapped pin/goupille taraudé	4		steel/Acier		0,01
700-004	317111-JLA-700-004	"conductor in tube" support	3	A	-		0.03



REVISIONS				
ZONE	REV.	DESCRIPTION	DATE	APPROUVE
	D	evolution of components	09/07/2012	
	E	added "conductor in tube" supports	29/10/2012	

 SIGMAPHI <i>zi du p'ral</i> Rue des frères Mongollier F-56000 Vannes	Name	M. Delbecq	Date	22/04/2013
	Drawing			
	Checked			
Tel:(33) 02.97.01.08.80 Fax (33)02.97.01.08.81 EMAIL Contact@sigmaphi.fr		MATERIAL:	-	
		Trait.:		
		Roughness:		
		Toi Gen		
		Supplier:		
		Weight:	13369.42 Kg	
			0.00	
		File name:317111-JLA-700-001		
DWG NO.		317111-JLA-700-001		Rev:
				E
<small>This drawing may not be used without special licence or authorisation express (Law of the 11 march 1957)</small>				

COUPE D-D
ECHELLE 1 : 50

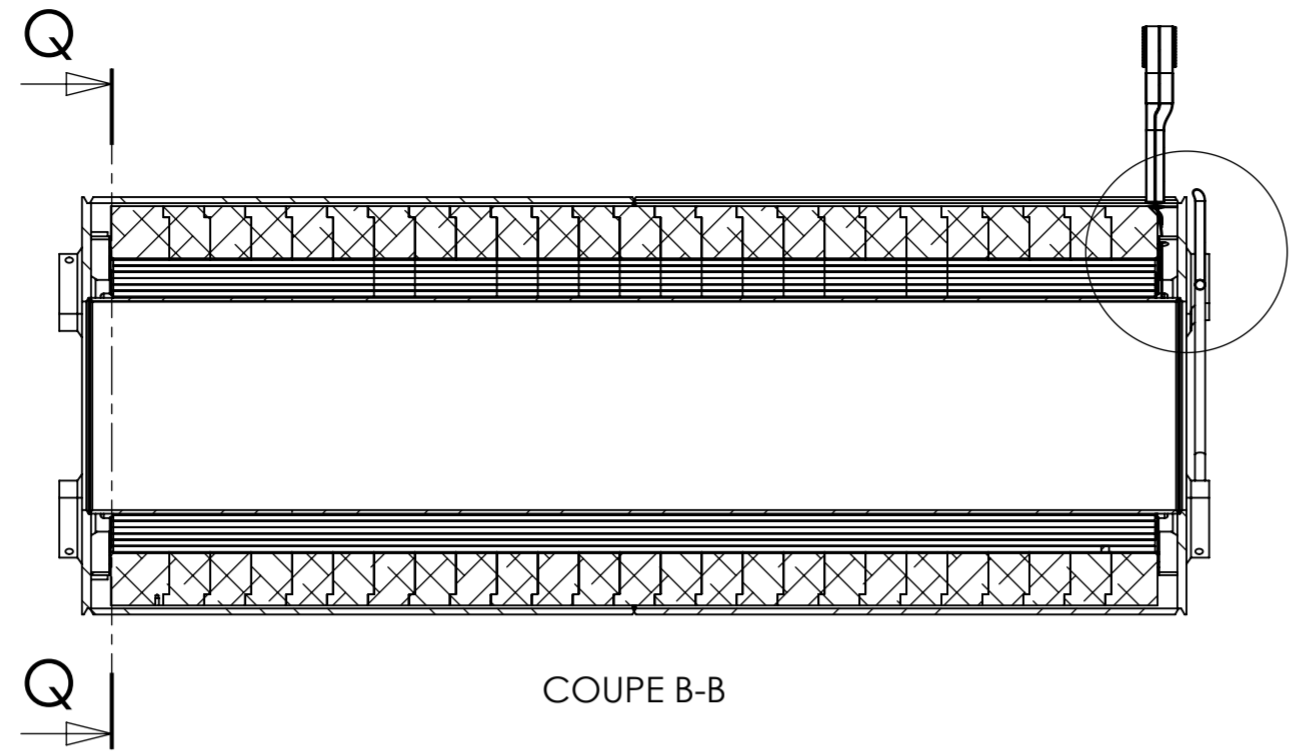
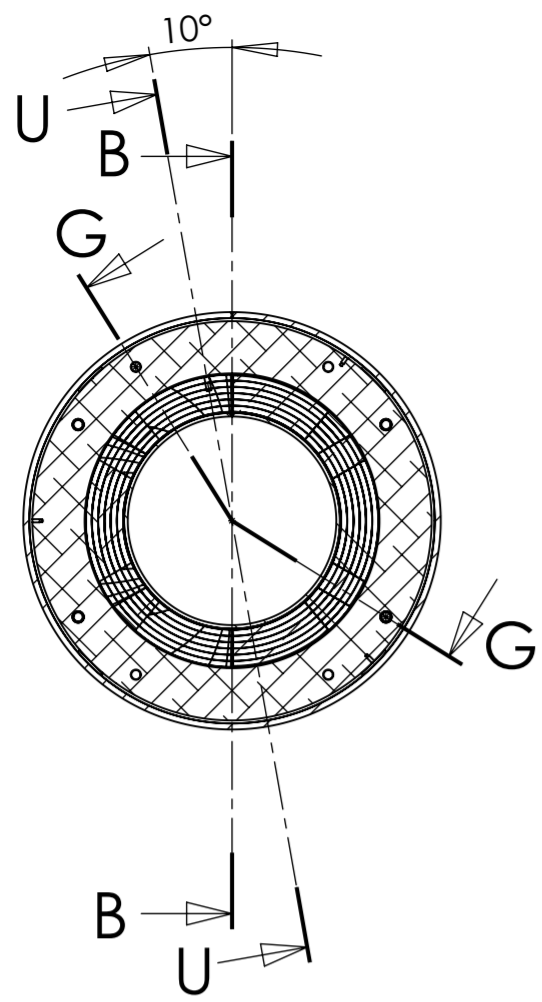

COUPE B-B

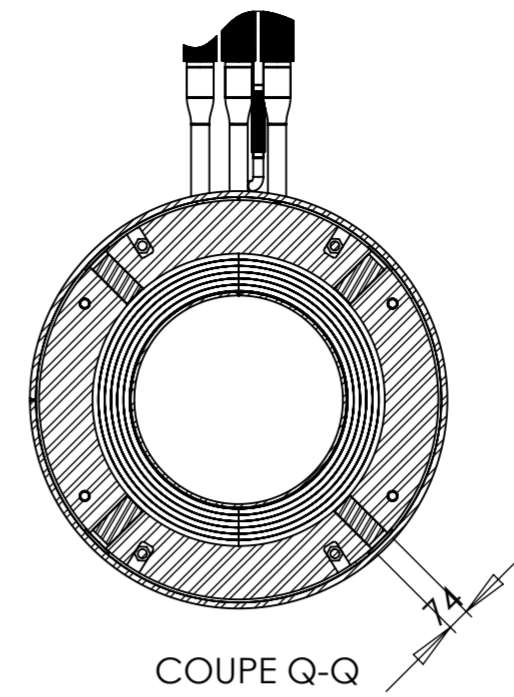

COUPE Q-Q

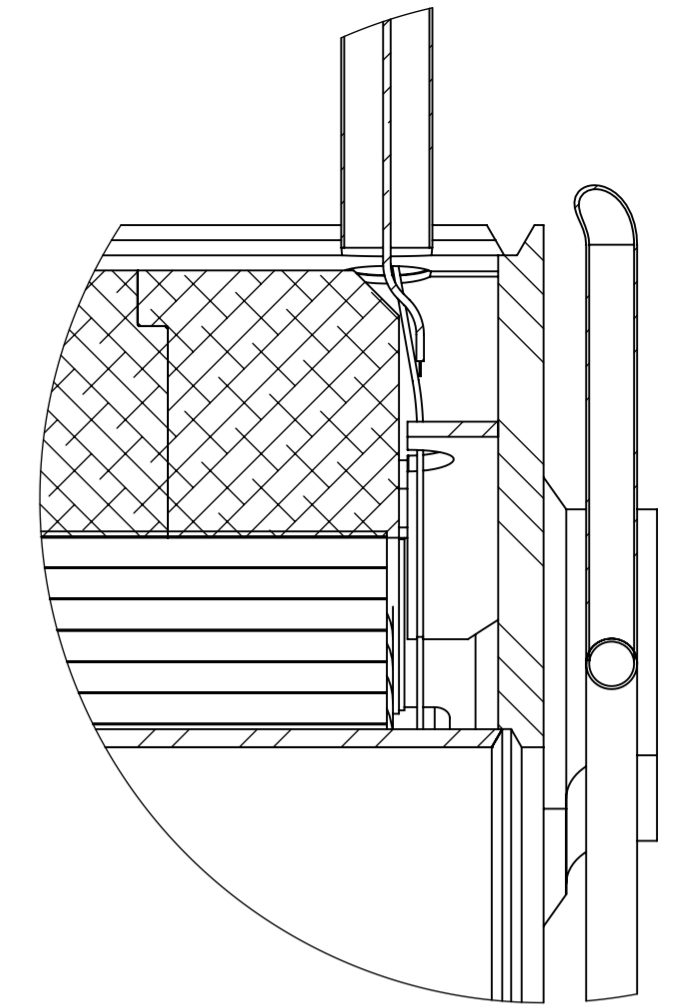

DÉTAIL I
ECHELLE 1 : 5

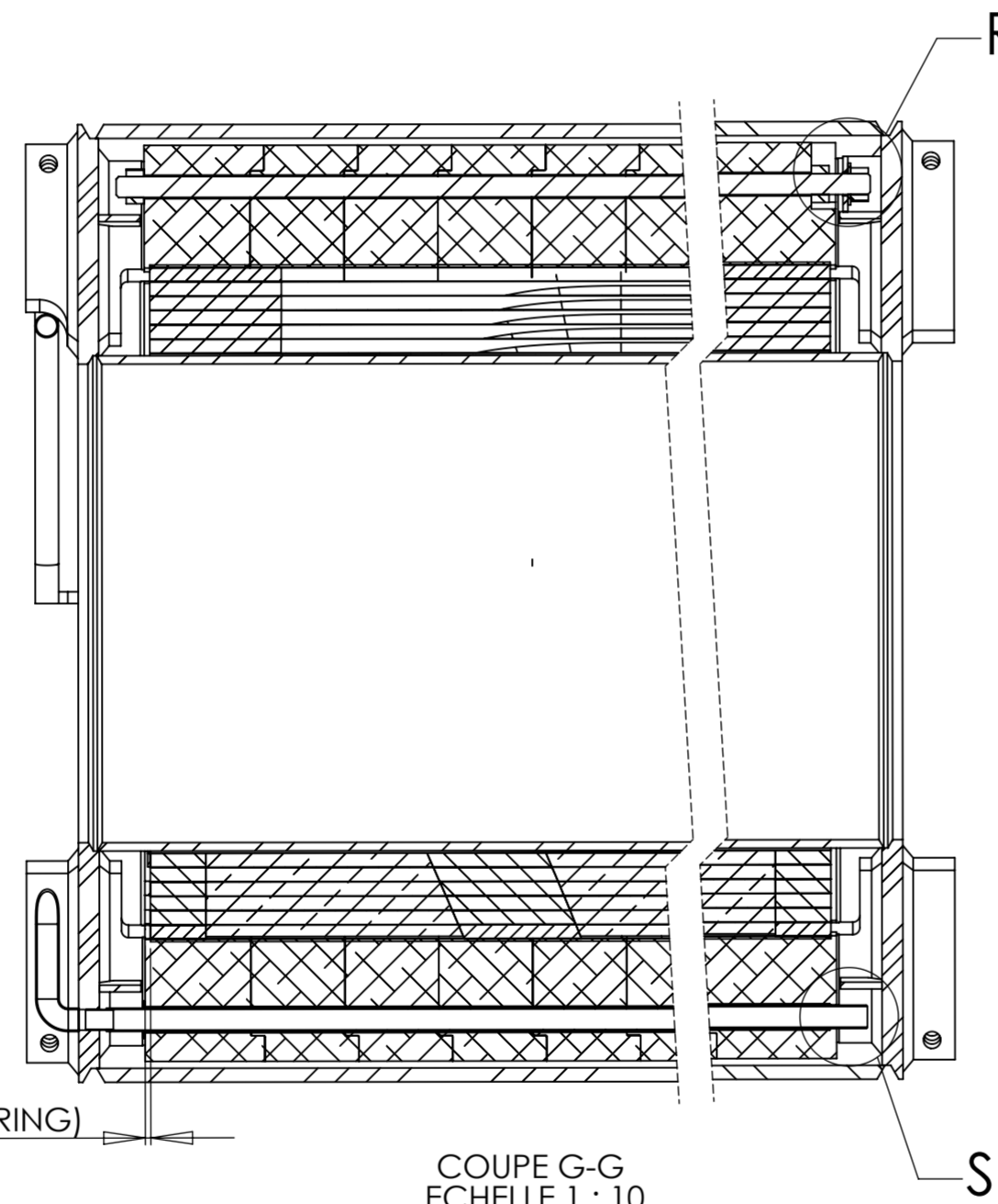
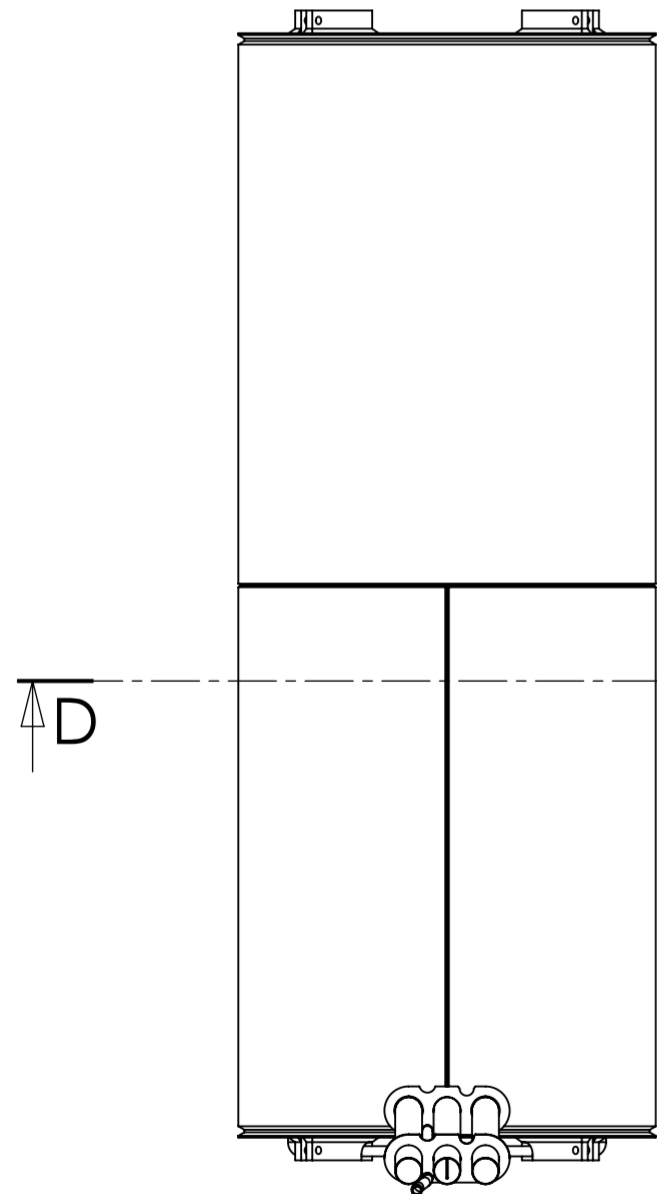

COUPE G-G
ECHELLE 1 : 10

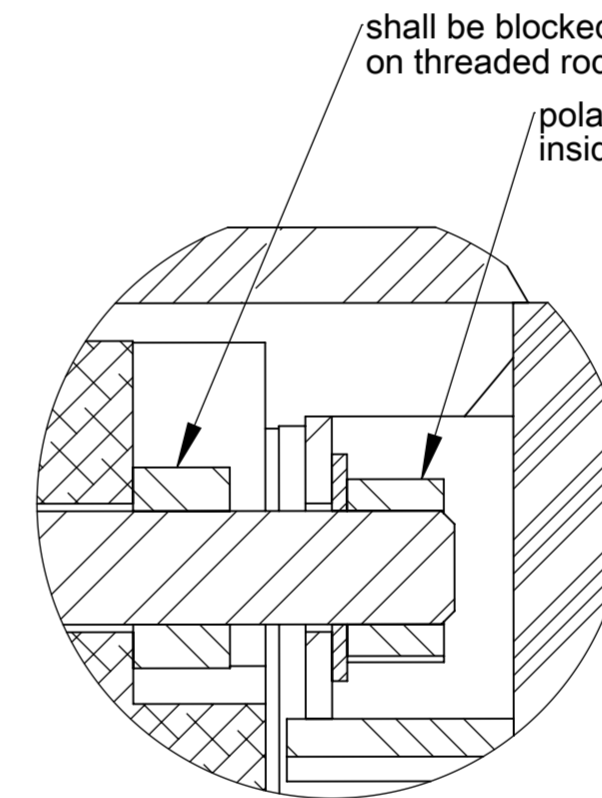

DÉTAIL R
ECHELLE 1 : 2

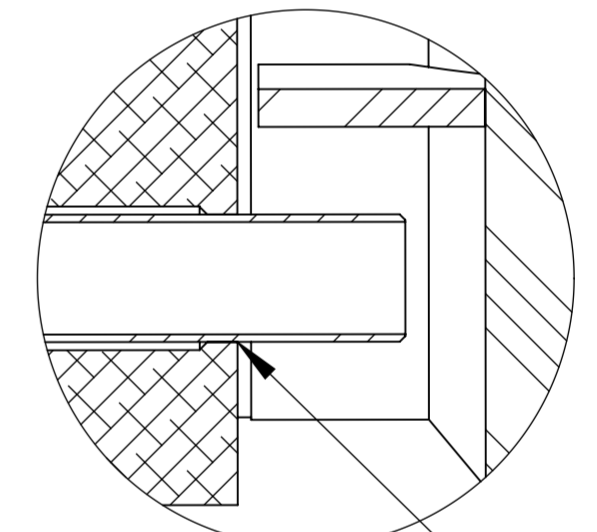

DÉTAIL S
ECHELLE 1 : 2

8 (COIL TO FORCE RING)

45 inside
spacers

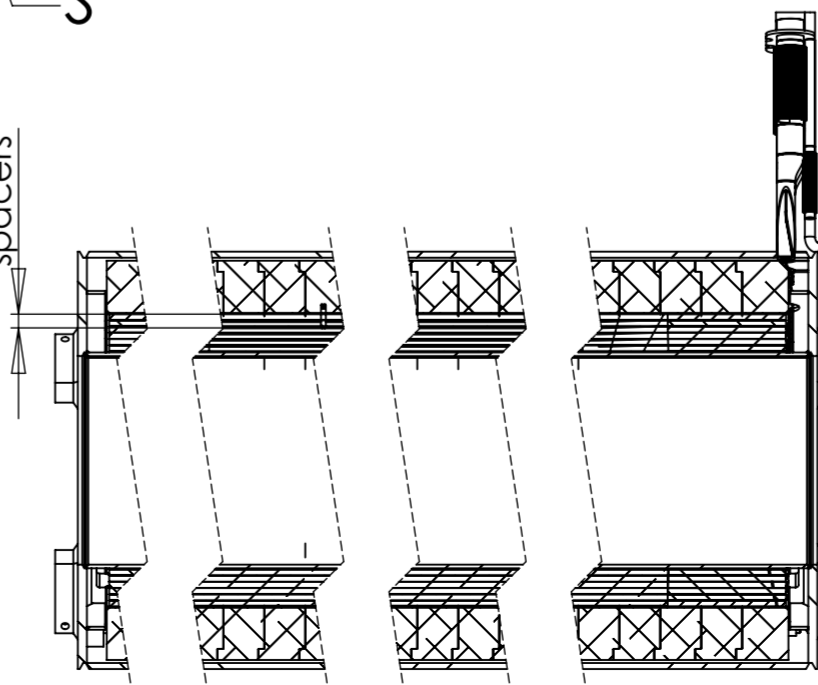

COUPE U-U

 <p>SIGMAPHI zi du prai Rue des frères Mongollier F-56000 Vannes</p> <p>Tel(33) 02.97.01.08.80 Fax (33)02.97.01.08.81 EMAIL Contact@sigmaphi.fr</p>	Name	Date
	Drawing	22/04/2013
	Checked	M. Delbecq
	Approved	
<p>DIPOLE SHMS</p>		<p>MATERIAL: -</p> <p>Trait.:</p> <p>Roughness:</p> <p>Tol Gen</p> <p>Supplier:</p> <p>Weight: 13369.42 Kg</p> <p>0.00</p> <p>File name:317111-JLA-700-001</p>
<p>DWG NO. 317111-JLA-700-001</p>		<p>Rev. E</p>
<p>This drawing may not be used without special licence or authorisation express (Law of the 11 march 1957)</p>		