

A and B have to be considered as surfaces from ends to 20mm

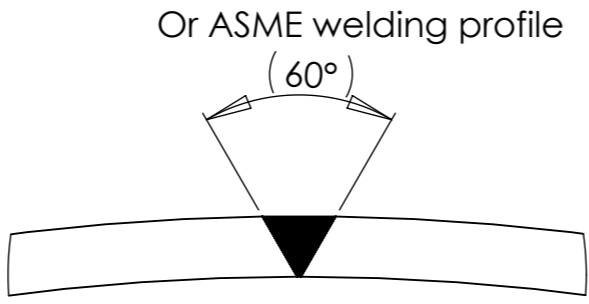

DÉTAIL A
ECHELLE 1 : 1

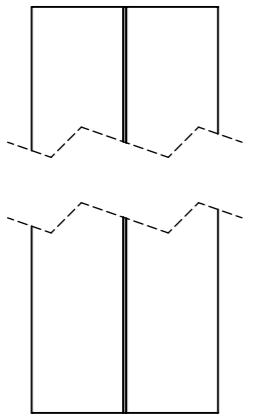
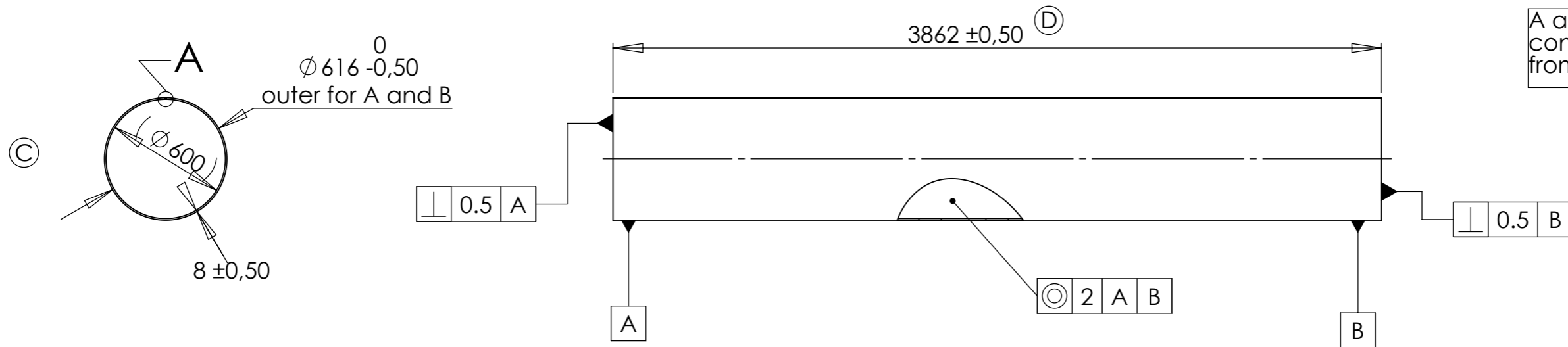
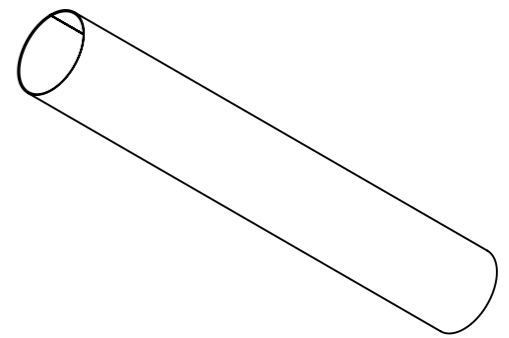

REVISIONS				
ZONE	REV.	DESCRIPTION	DATE	APPROUVE
	C	change of the thickness	26/04/2012	
	D	CHANGED THE LENGHT	20/06/2012	
	F	added precisions	13/11/2012	

 ZI du prat Rue des frères Mongolfier F-56000 Vannes Tel(33) 02.97.01.08.80 Fax (33)02.97.01.08.81 EMAIL Contact@sigmaphi.fr	Name		Date	
	Drawing	M. Delbecq	16/04/2013	
	Checked			
	Approved			
	MATERIAL:	Inox/Stainless steel 304L		
	Trait.:			
	Roughness :			
	Tol Gen	±2		
	Supplier:			
	Weight:	430.54 Kg		
		0.00		
	File name:	317111-JLA-701-003		
DWG NO.	317111-JLA-701-003			Rev:
				F
This drawing may not be used without special licence or authorisation express (Law of the 11 march 1957)				 A3 SCALE:1:25 SHEET 1 OF 1