

COUPE A-A

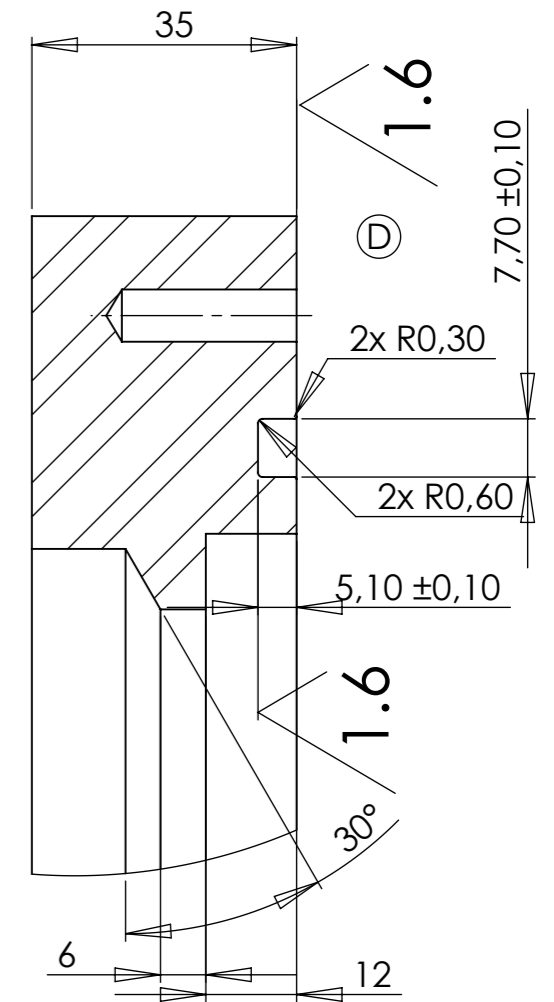

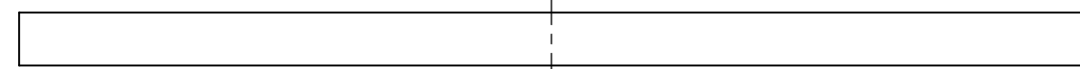

DÉTAIL B
ECHELLE 1 : 1

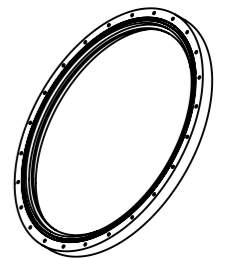

REVISIONS

ZONE	REV.	DESCRIPTION	DATE	APPROUVE
	C	suppressed joint-groove on one side	26/04/12	
	D	SIMPLIFIED THE PART: SUPPRESSION OF WELDING LIPS	21/06/2012	

 <p>ZI du prat Rue des frères Mongolfier F-56000 Vannes</p> <p>Tel(33) 02.97.01.08.80 Fax (33)02.97.01.08.81 EMAIL Contact@sigmaphi.fr</p>	Name	M. Delbecq	Date	16/04/2013
	Drawing			
	Checked			
	Approved			
	MATERIAL:	Inox/Stainless steel 304L		
	Trait.:			
	Roughness :			
	Tol Gen	+/-0.2		
	Supplier:			
	Weight:	23.16 Kg		
		ERREUR:SW_Mas/Vo		
		File name:317111-JLA-701-008		
DWG NO.	317111-JLA-701-008			Rev:
				D
This drawing may not be used without special licence or authorisation express (Law of the 11 march 1957)				 A3 SCALE:1:5 SHEET 1 OF 1