

REVISIONS				
ZONE	REV.	DESCRIPTION	DATE	APPROUVE
	D	changed bending angles, radius and added notes	27/06/2012	A
	E	changed final height	15/04/2013	

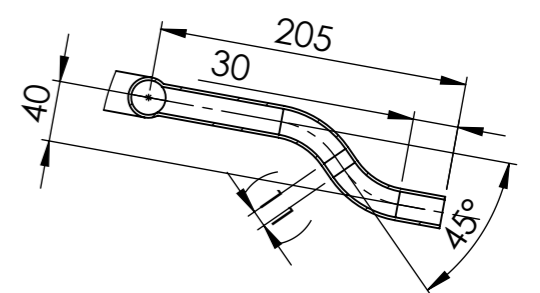

COUPE B-B
ECHELLE 1 : 5

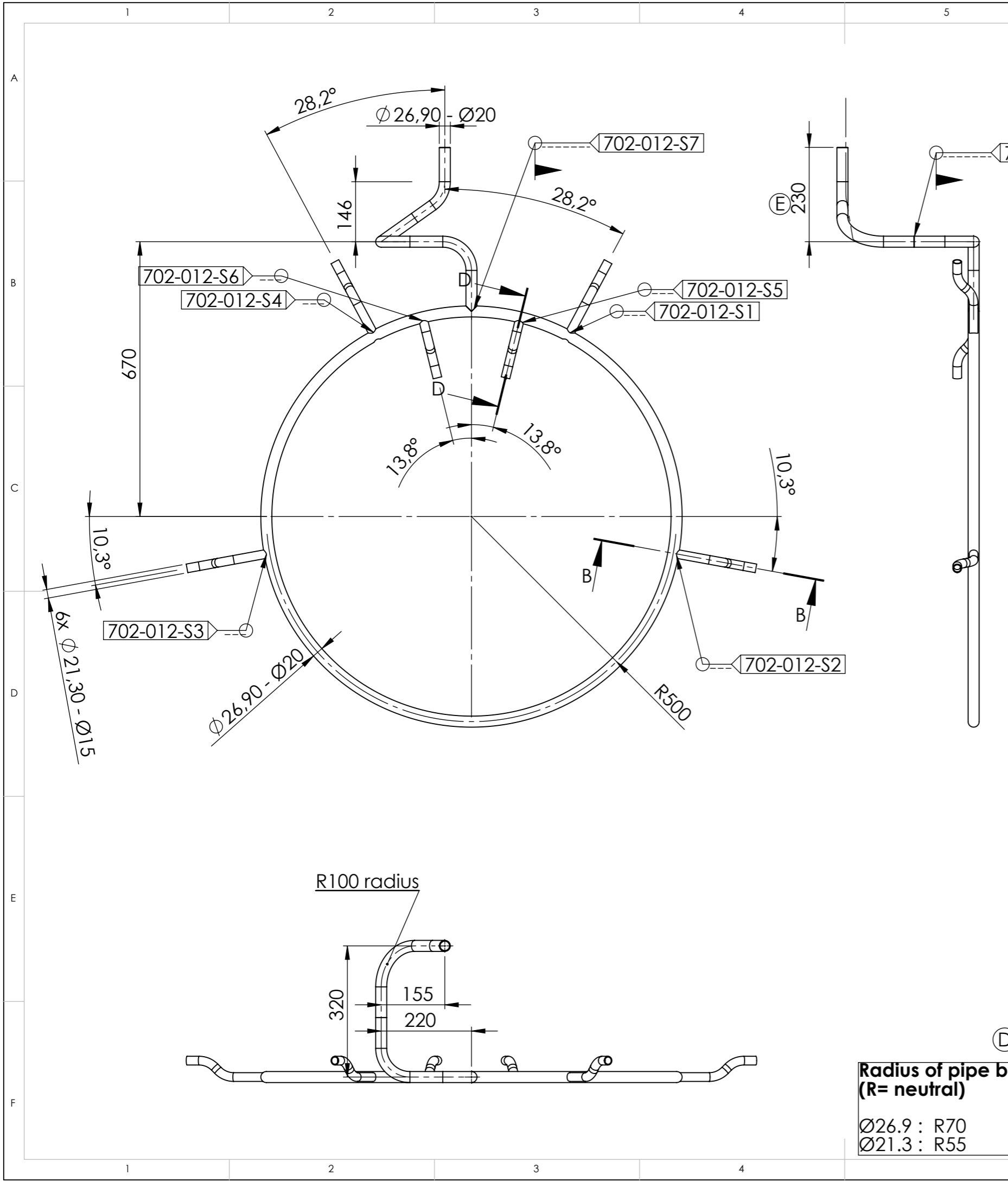
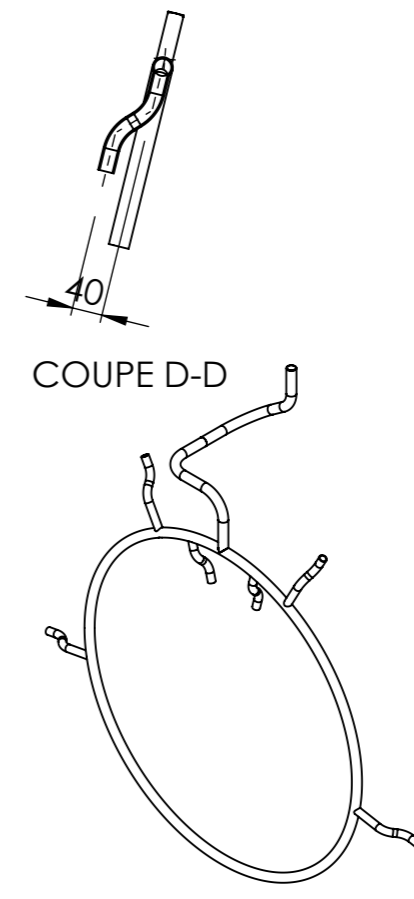

COUPE D-D

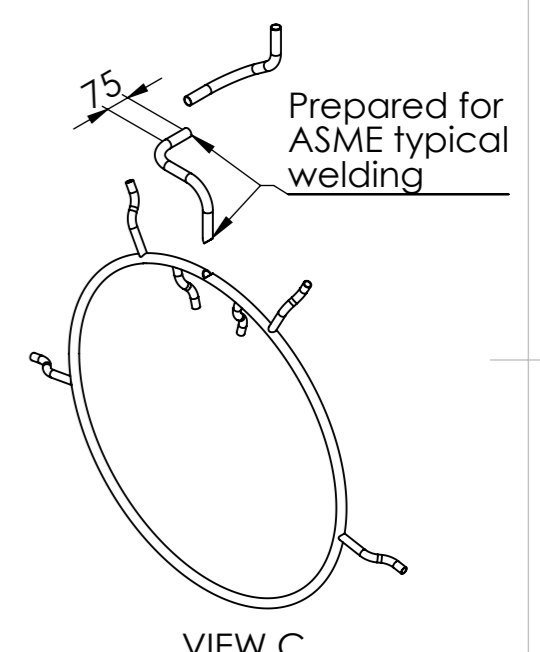

VIEW C

NOTE:
 - Content liquid nitrogen at 70°K.
 - Design pressure: 6atm absolute from 60°K to 300°K.
 - Design and manufacturing according to AMSE BPV.
 - Shall be delivered in the state shown at view "C" (in 3 parts)

**Radius of pipe bending
(R= neutral)**
 Ø26.9 : R70
 Ø21.3 : R55

 ZI du prat Rue des frères Mongolfier F-56000 Vannes Tel(33) 02.97.01.08.80 Fax (33)02.97.01.08.81 EMAIL Contact@sigmaphi.fr	Name	M. Delbecq	Date	16/04/2013
	Drawing			
	Checked			
	Approved			
	MATERIAL:	Inox/Stainless steel 304L		
	Trait.:			
	Roughness :			
	Tol Gen	+/- 1		
	Supplier:			
	Weight:	5.58 Kg		
		0.00		
	File name:	317111-JLA-702-012		
DWG NO.	317111-JLA-702			Rev:
				E
This drawing may not be used without special licence or authorisation express (Law of the 11 march 1957)				A3 SCALE:1:10 SHEET 1 OF 1