

REP	REFERENCE	DESIGNATION	QTY	REV	MATERIAL	SUPPLIER	MASS (Kg)
703-002	317111-JLA-703-002	OUTER TUBE	1	F	304L (X2CrNi18-9)		2413.17
703-003	317111-JLA-703-003	INNER TUBE	1	E	Inox/Stainless steel 304L		692.97
703-004	317111-JLA-703-004	FLANGE SIDE END	1	G	304L (X2CrNi18-9)		360.33
703-005	317111-JLA-703-005	FLANGE SIDE ARRIVAL	1	G	304L (X2CrNi18-9)		352.46
703-006	317111-JLA-703-006	UPPER PIPES	1	E	304L (X2CrNi18-9)		2.11
703-008	317111-JLA-703-008	HELIUM VESSEL NECK S/A	1	E	See assembly		64.24
703-013	317111-JLA-703-013	OMEGA PIPING	1	F	304L (X2CrNi18-9)		4.71
703-046	317111-JLA-703-046	Pipe sub-assembly	4	A	See assembly		5.65
9011	5933-Réduction-excentrique-2-3pouces-ANSI-10S	réduction excentrique ANSI 10S	3		304L (X2CrNi18-9)		0.48

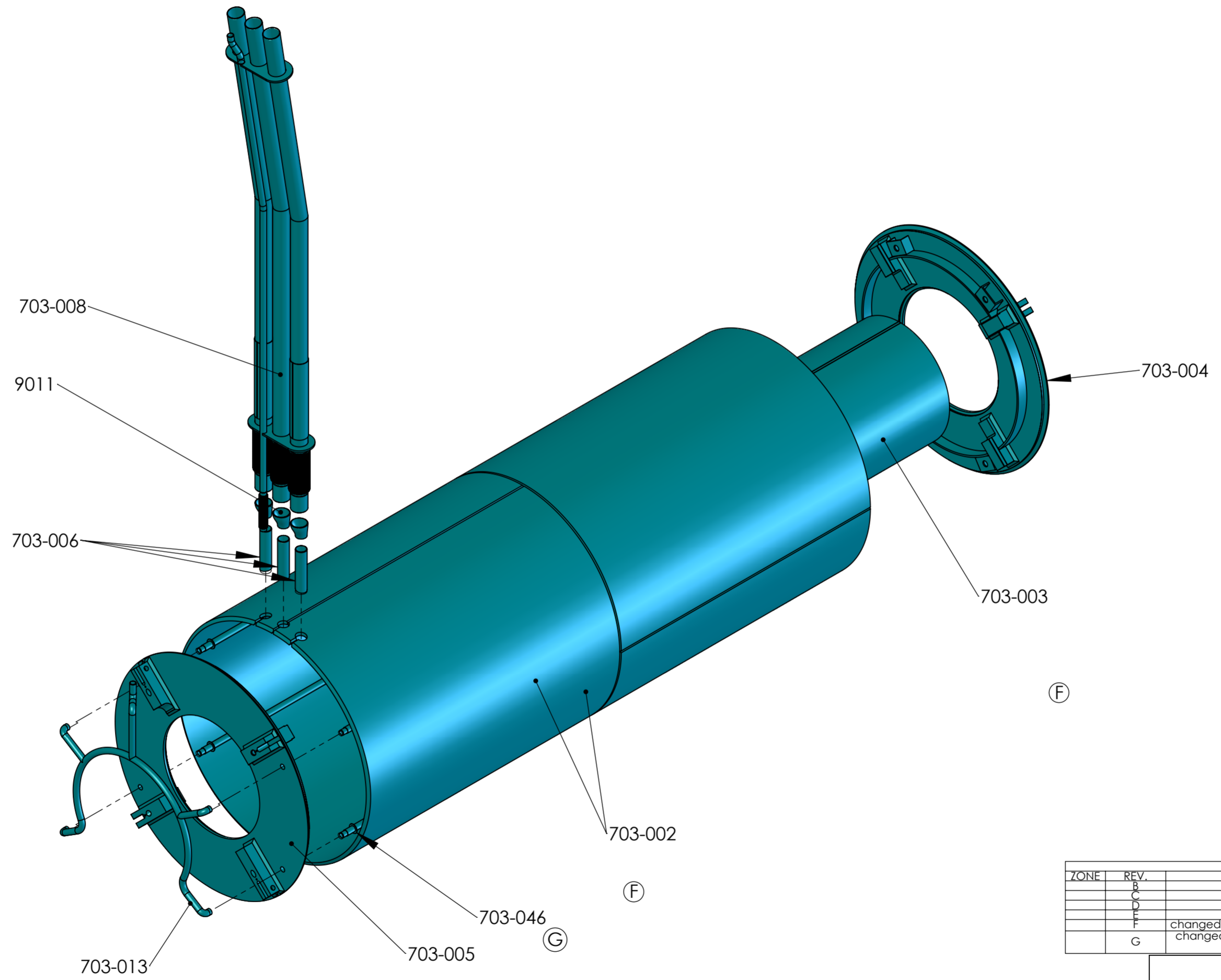

ZONE	REV.	DESCRIPTION	DATE	APPROUVE
	B	WELDING FRAME CHANGED FOR IDR	14/01/2011	
	C	CHANGED REVISION OF PARTS	03/05/2012	
	D	ADDED INTERNAL WELDING FOR PIPES	22/05/2012	
	E	CHANGED WELDING DEFINITION	11/06/2012	
	F	changed thickness of ext. vessel and added stiffening rings	23/10/2012	
	G	changed thickness of ext. vessel, removed stiffening rings and added pipes sub-assembly	17/04/2013	

SIGMAPHI <i>zi du pral</i> Rue des frères Mongollier F-56000 Vannes		
Name	M. Delbecq	Date
Drawing		17/04/2013
Checked		
Approved		
Trait.:	See assembly	
Roughness:		
Toi Gen		
Supplier:		
Weight:	3911.99 Kg	
	0.00	
File name: 317111-JLA-703-001		

NOTE:
- Content liquid helium at 4°K.
- Design pressure: 6atm absolute from 4°K to 300°K.
- Design and manufacturing according to AMSE BPV.

DWG NO.	317111-JLA-703-001	Rev.	G
<small>This drawing may not be used without special licence or authorisation express (Law of the 11 march 1957)</small>			
A2		SCALE: 1:100	SHEET 1 OF 3

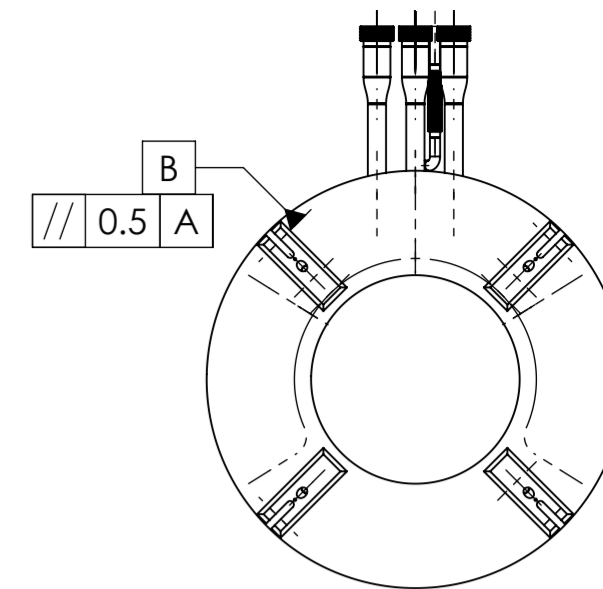
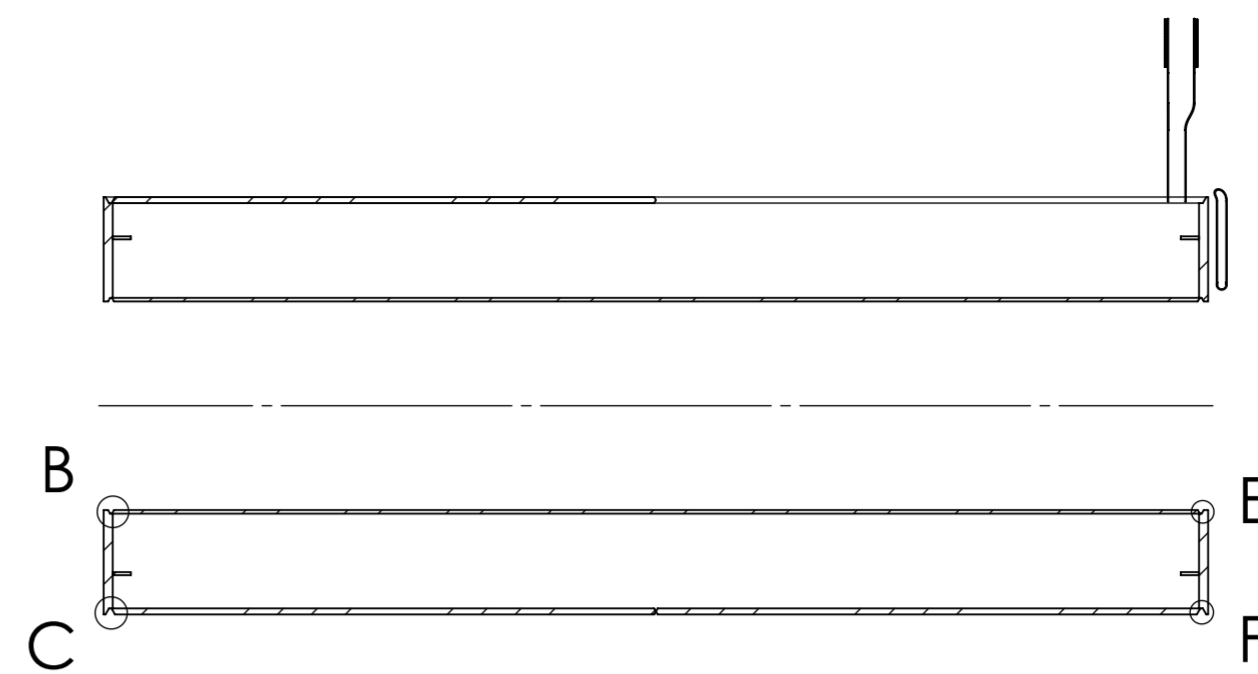
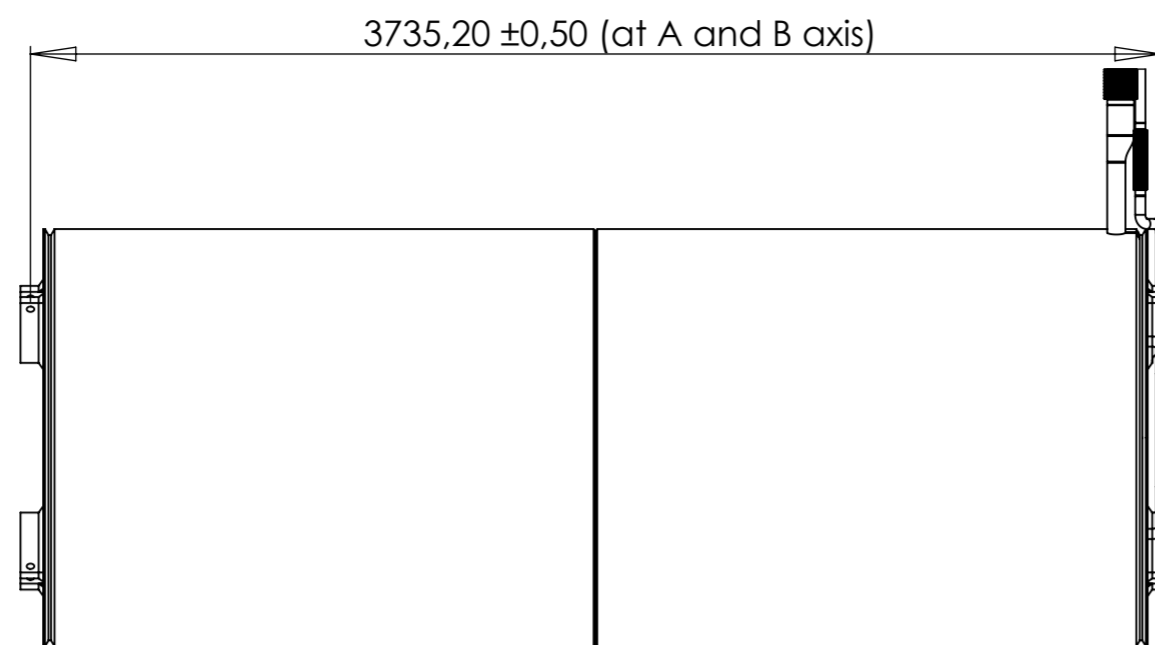
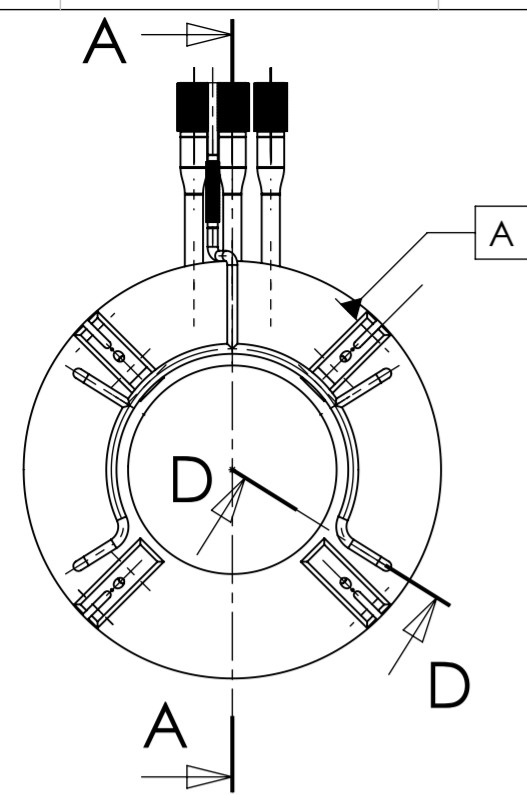

COUPE A-A

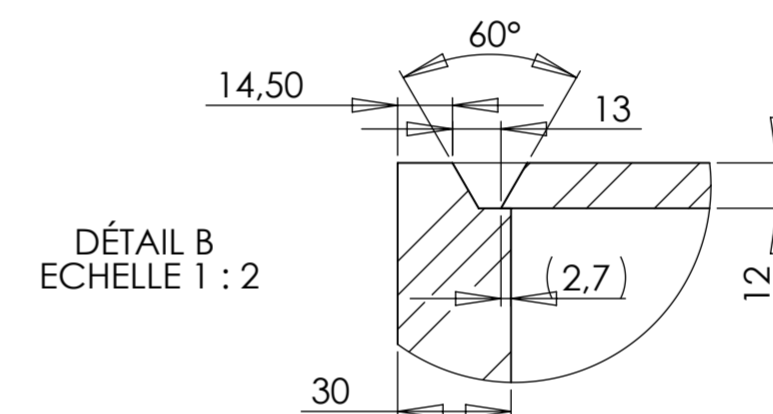
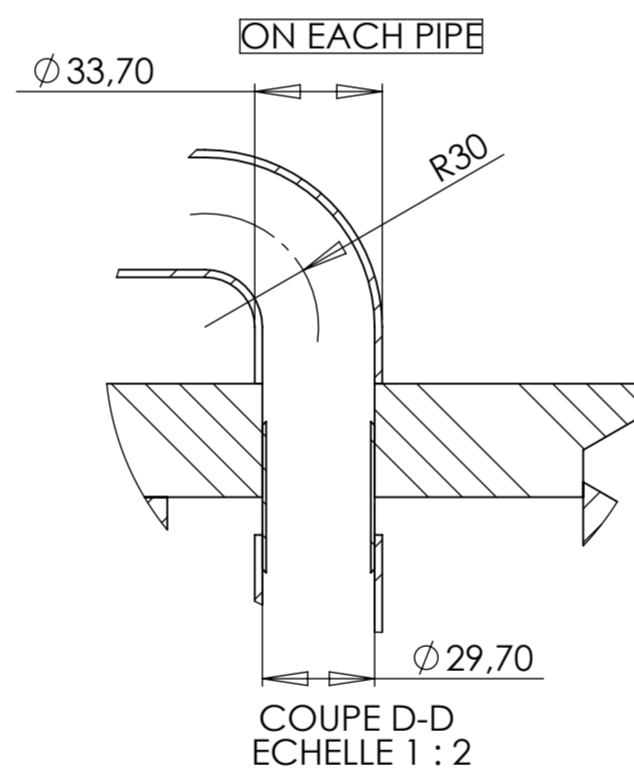
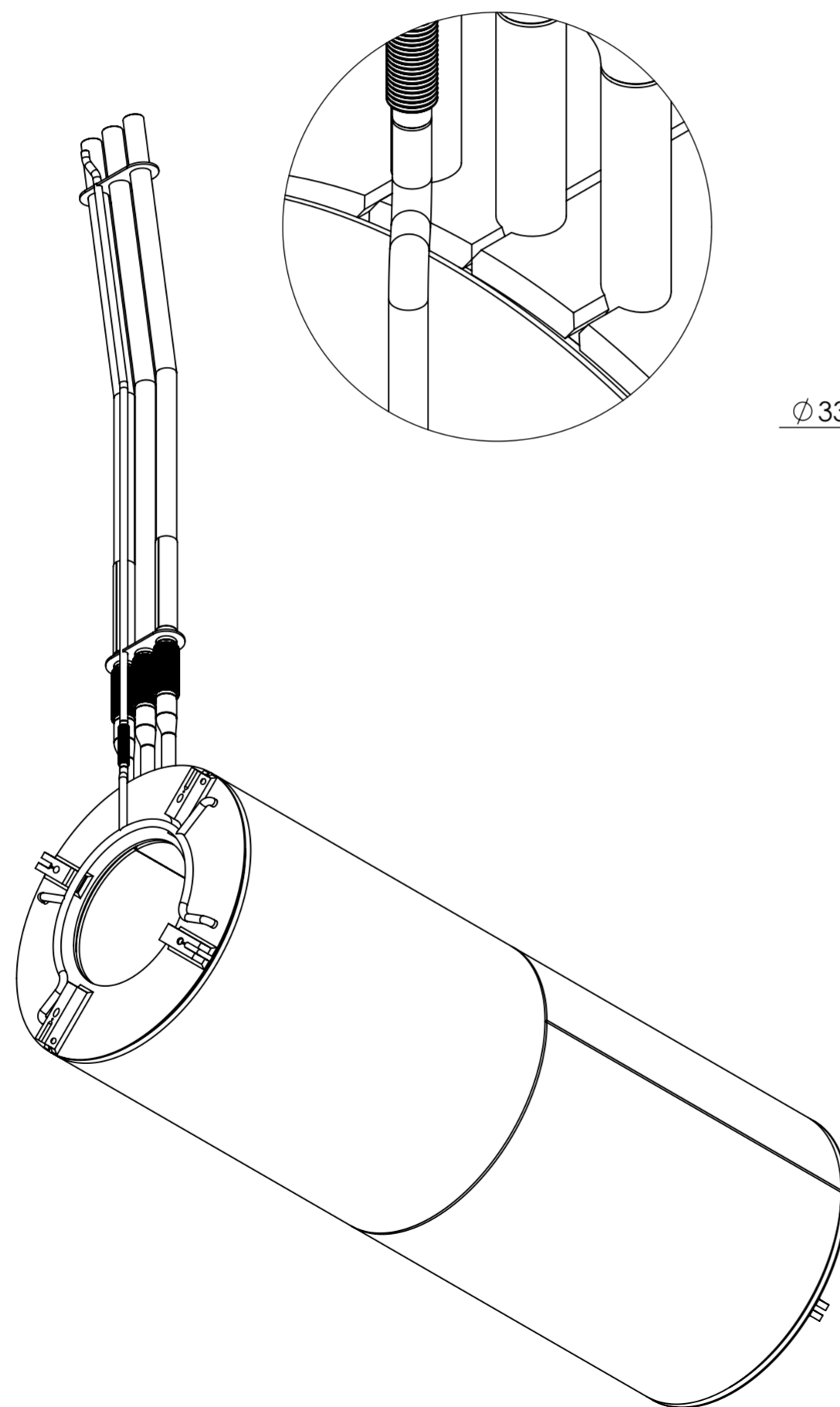
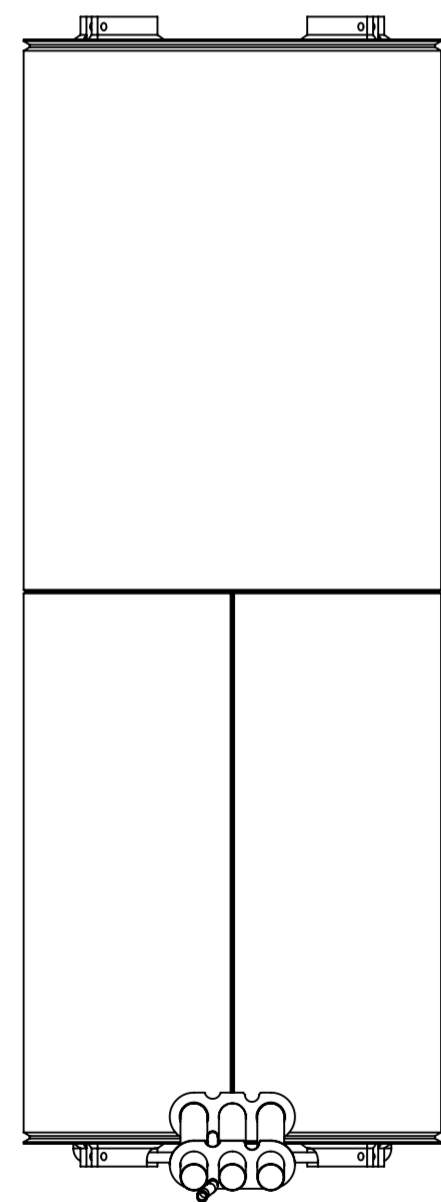

DÉTAIL C
 ECHELLE 1 : 2

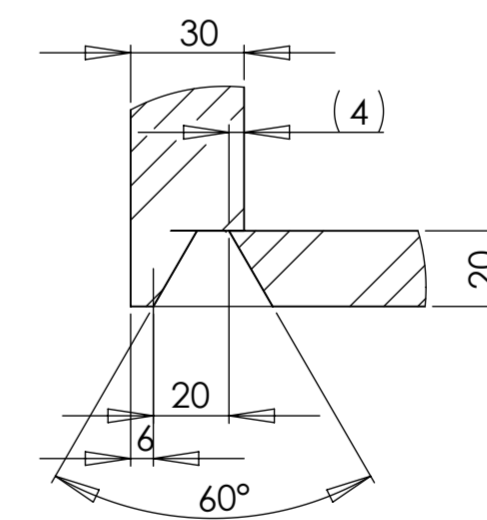

 SIGMAPHI <small>INDUSTRIE DES BÂTIMENTS TRANSPORT</small> Tel(33) 02.97.01.08.80 Fax (33)02.97.01.08.81 EMAIL Contact@sigmaphi.fr	SIGMAPHI zi du prai Rue des frères Mongollier F-56000 Vannes		Name	Date
	Drawing	M.Delbecq	17/04/2013	
	Checked			
	Approved			
COLD MASS		MATERIAL:	See assembly	
He VESSEL		Trait.:		
		Roughness:		
		Tol Gen:		
		Supplier:		
		Weight:	3911.99 Kg	
			0.00	
		File name:	317111-JLA-703-001	
DWG NO. 317111-JLA-703-001		Rev:	G	
<small>This drawing may not be used without special licence or authorisation express (Law of the 11 march 1957)</small>		SCALE:1:25	SHEET 2 OF 3	

NOTE DE SOUDURE	LONGUEUR DE SOUDURE
703-001-S10	83.03
703-001-S13	13.17
703-001-S18	3948.92
703-001-S19	4198.06
703-001-S20	2226.32
703-001-S21	4452.55
703-001-S33	93.31
703-001-S34	105.87
703-001-S35	105.87
703-001-S36	105.87
703-001-S37	105.87
703-001-S38	98.09
703-001-S12	13.17
703-001-S10	83.03
703-001-040	189.48
703-001-S41	189.48
703-001-S42	189.48
703-001-S43	271.38
703-001-S44	271.38
703-001-S45	271.38
703-001-S9	172.71
703-001-S11	172.71
703-001-S30	93.31
703-001-S31	93.31
703-001-S34	93.31

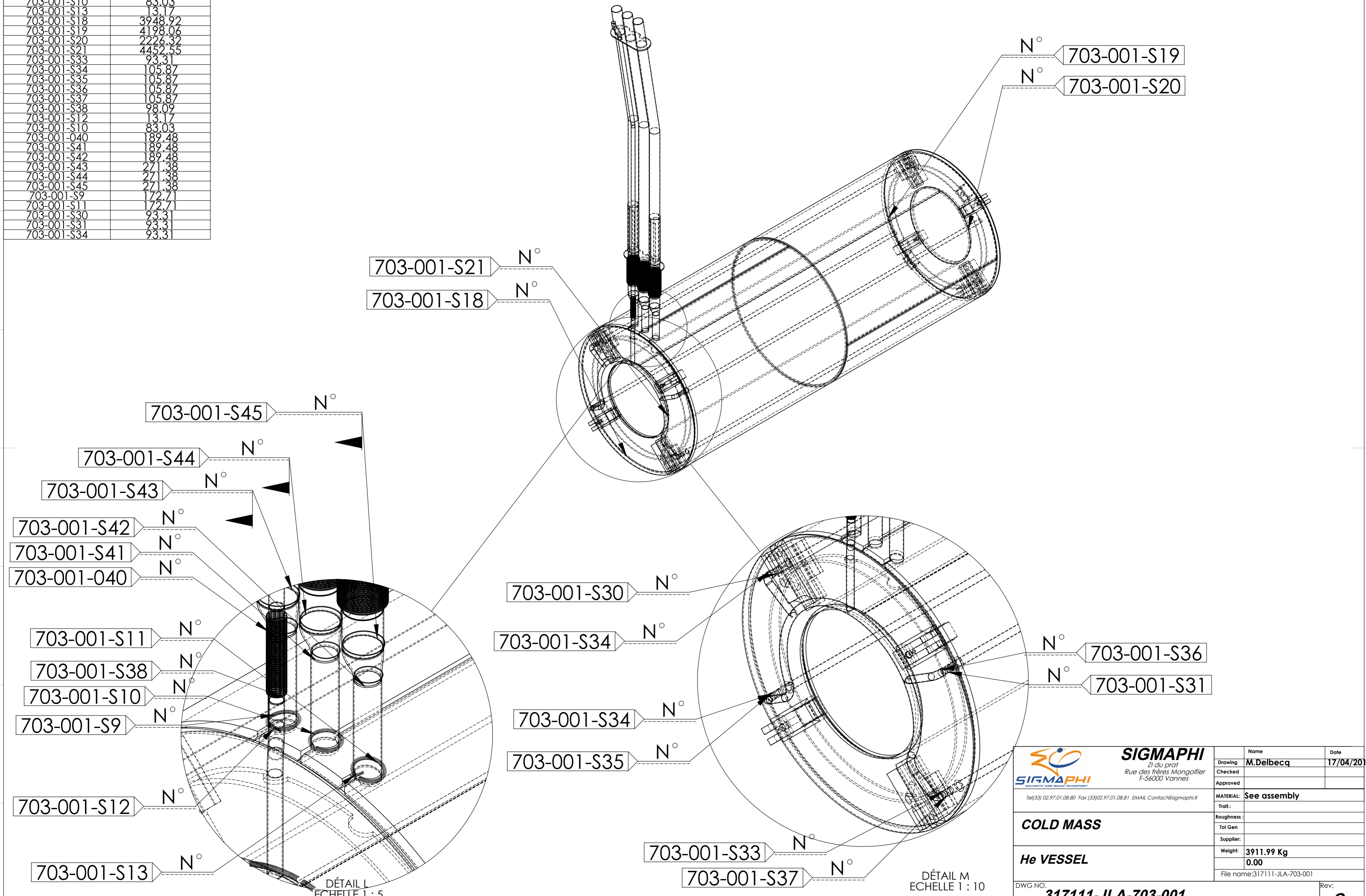

DÉTAIL D
ECHELLE 1 : 5

DÉTAIL M
ECHELLE 1 : 10

 SIGMAPHI <i>zi du pral</i> Rue des frères Mongollier F-56000 Vannes	Name	M. Delbecq	Date	17/04/2013
	Drawing			
	Checked			
	Approved			
MATERIAL: See assembly				
Trait.:				
Roughness:				
Toi Gen				
Supplier:				
Weight:		3911.99 Kg		
		0.00		
File name: 317111-JLA-703-001				
DWG NO. 317111-JLA-703-001		Rev: G		
This drawing may not be used without special licence or authorisation express (Law of the 11 march 1957)				