

1	2	3	4	5	6	7	8
REP	REFERENCE	DESIGNATION	QTE	IND	MATIERE	FOURNISSEUR	MASSE
704-002	317111-JLA-704-002	END FORCE RING 1	1	E	ALU 5083		263.57
704-004	317111-JLA-704-004	FORCE RING	23	F	ALU 5083		229.04
704-005	317111-JLA-704-005	END FORCE RING 2	1	F	ALU 5083		314.35
704-006	317111-JLA-704-006	Tie rods	4	A	Inox/Stainless steel 304L		18.31
9005	Ecrou H M 30 Inox 304L	NVI9000	8		Inox/Stainless steel 304L		0.23

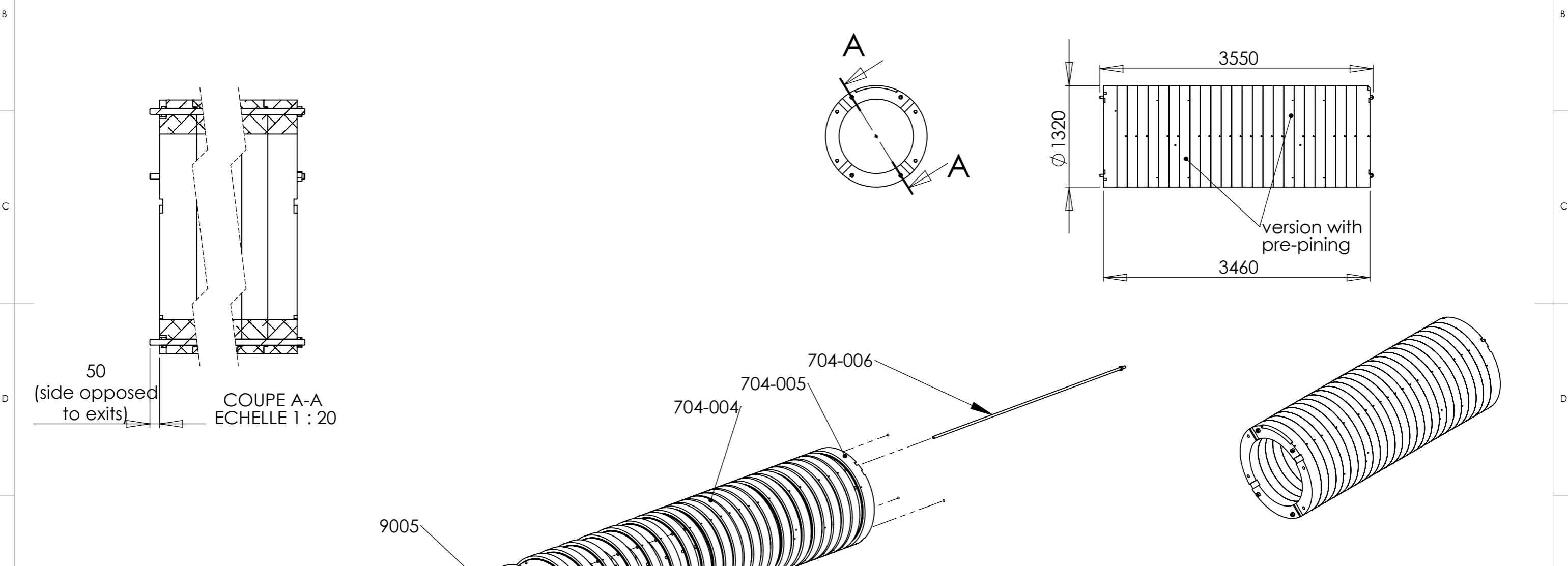

REVISIONS				
ZONE	REV.	DESCRIPTION	DATE	APPROUVE
	E	Change of components revision	06/11/2012	

<p>ZI du prat Rue des frères Mongolfier F-56000 Vannes</p> <p>Tel(33) 02.97.01.08.80 Fax (33)02.97.01.08.81 EMAIL Contact@sigmaphi.fr</p>	Name	M. Delbecq	Date	16/04/2013
	Drawing			
	Checked			
	Approved			
	MATERIAL:	See assembly		
	Trait.:			
	Roughness :			
	Tol Gen			
	Supplier:			
	Weight:	5920.59 Kg		
		0.00		
	File name:	317111-JLA-704-001		
DWG NO.	317111-JLA-704-001			Rev:
				E
This drawing may not be used without special licence or authorisation express (Law of the 11 march 1957)				
	A3	SCALE:1:50	SHEET 1 OF 1	