

REVISIONS				
ZONE	REV.	DESCRIPTION	DATE	APPROUVE
	A1	CHANGES FOR INTERMEDIARY DESIGN REVIEW	20/10/2011	
	C	changed thickness	03/05/2012	
	D	CHANGED WELDING PREPARATION	04/06/2012	
	E	ADDED TOLERANCES ON THICKNESS	06/11/2012	
	F	changed lenght	29/08/2013	

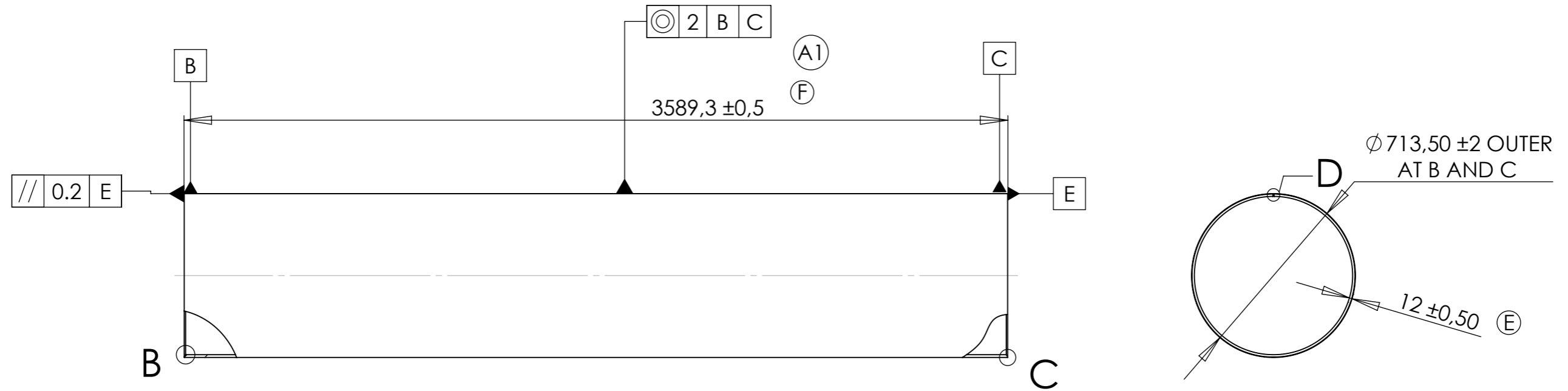

B and C have to be considered as surfaces from ends to 20mm

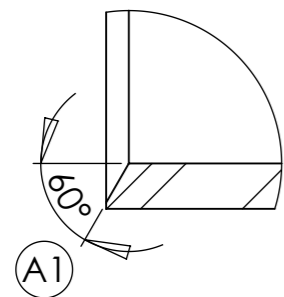

DÉTAIL B
ECHELLE 1 : 2

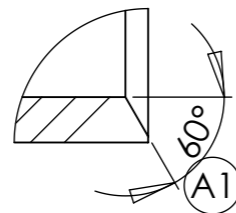

DÉTAIL C
ECHELLE 1 : 2

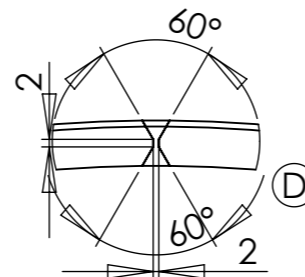

DÉTAIL D
ECHELLE 1 : 2

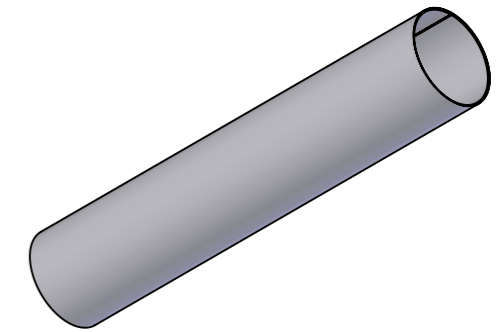

FOR INFORMATION

Porhiet

 ZI du prat Rue des frères Mongolfier F-56000 Vannes Tel(33) 02.97.01.08.80 Fax (33)02.97.01.08.81 EMAIL Contact@sigmaphi.fr	Name		Date	
	Drawing	M Delbecq	10/10/2013	
	Checked			
	Approved			
	MATERIAL:	304L (X2CrNi18-9)		
	Trait.:			
	Roughness :			
	Tol Gen	±2		
	Supplier:			
	Weight:	748.42 Kg		
		0.00		
	File name:	317111-JLA-703-003		
DWG NO.	317111-JLA-703-003			Rev:
				F
This drawing may not be used without special licence or authorisation express (Law of the 11 march 1957)				A3 SCALE:1:20 SHEET 1 OF 1