

FOR INFORMATION

Parhiel

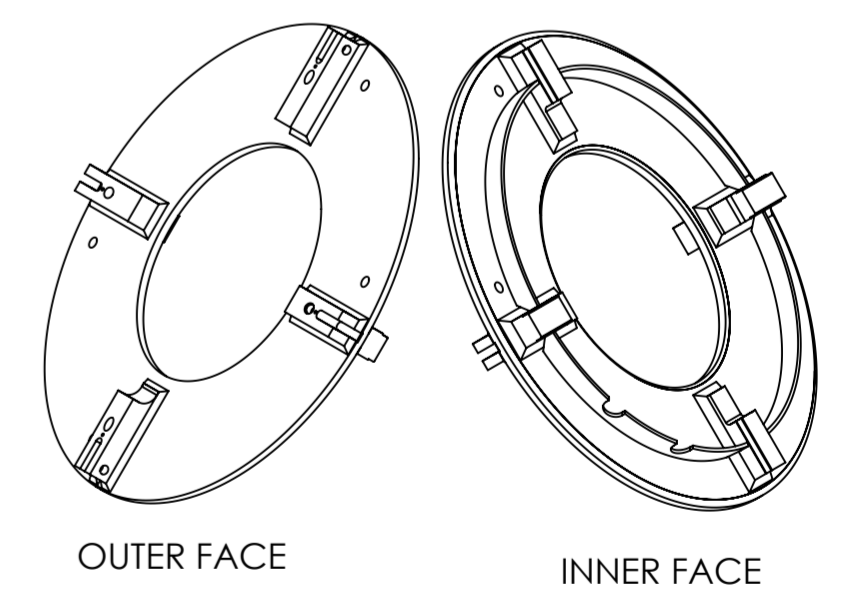

| REVISIONS | | | | |
|-----------|------|---|------------|----------|
| ZONE | REV. | DESCRIPTION | DATE | APPROUVE |
| | A1 | CHANGES FOR INTERMEDIARY DESIGN REVIEW | 20/10/2011 | |
| | B1 | Ø30 => Ø25 | 19/12/2011 | |
| | C | INTERNAL AND EXTERNAL SUPPORTS IN ONE PART THROUGH THE FLANGE + CHANGE WELDING CHAMFERS | 03/05/2012 | |
| | D | CHANGE OF WELDING DEFINITION + 155=>190 + ADDED R8 + SUPPRESSED CHAMFERS + CHANGED Ø OF PIPE HOLES + CHANGED ANGLE OF M30 | 04/06/2012 | |
| | E | ADDED Ø8 for magnet measurement | 17/09/2012 | |
| | F | CHANGE PLOT TO 2 DIFFERENTS PARTS | 22/10/2012 | |
| | G | CHANGED WELDING DEFINITION | 15/03/2013 | |
| | H | CHANGED THICKNESS OF WELDINGS (10=>15) AND WELDING PROFILE | 29/08/13 | |

SIGMAPHI
zi du pyral
Rue des frères Mongollier
F-56000 Vannes

Tel:(33) 02.97.01.08.80 Fax (33)02.97.01.08.81 EMAIL Contact@sigmaphi.fr

Name: **M Delbecq** Date: **24/02/2014**

Drawing: **M Delbecq**

Checked: **M Delbecq**

Approved: **M Delbecq**

MATERIAL: **304L (X2CrNi18-9)**

Trait.:

Roughness:

Toi Gen: **+/-1**

Supplier:

Weight: **366.00 Kg**

0.00

File name:317111-JLA-703-005

He VESSEL

FLANGE SIDE ARRIVAL

DWG NO. **317111-JLA-703-005**

Rev: **1**

This drawing may not be used without special licence or authorisation express (Law of the 11 march 1957)