

A and B have to be considered as surfaces from ends to 20mm

REVISIONS			
REV.	DESCRIPTION	DATE	APPROUVE
A	CREATION (splitted from 703-002)	29/08/2013	MD
B	added tolerance on thickness	21/02/2014	MD

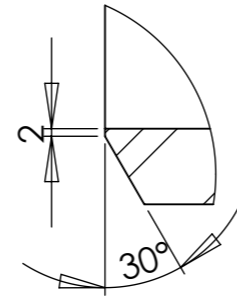

DÉTAIL A
ECHELLE 1 : 2

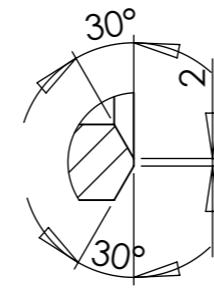

DÉTAIL J
ECHELLE 1 : 2

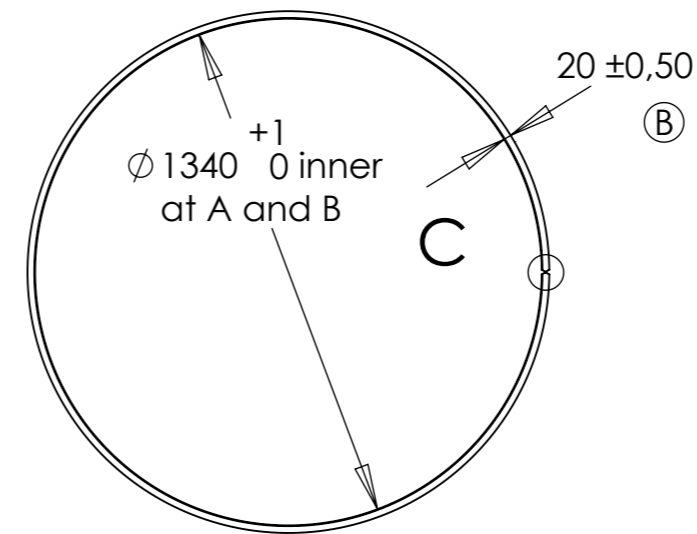
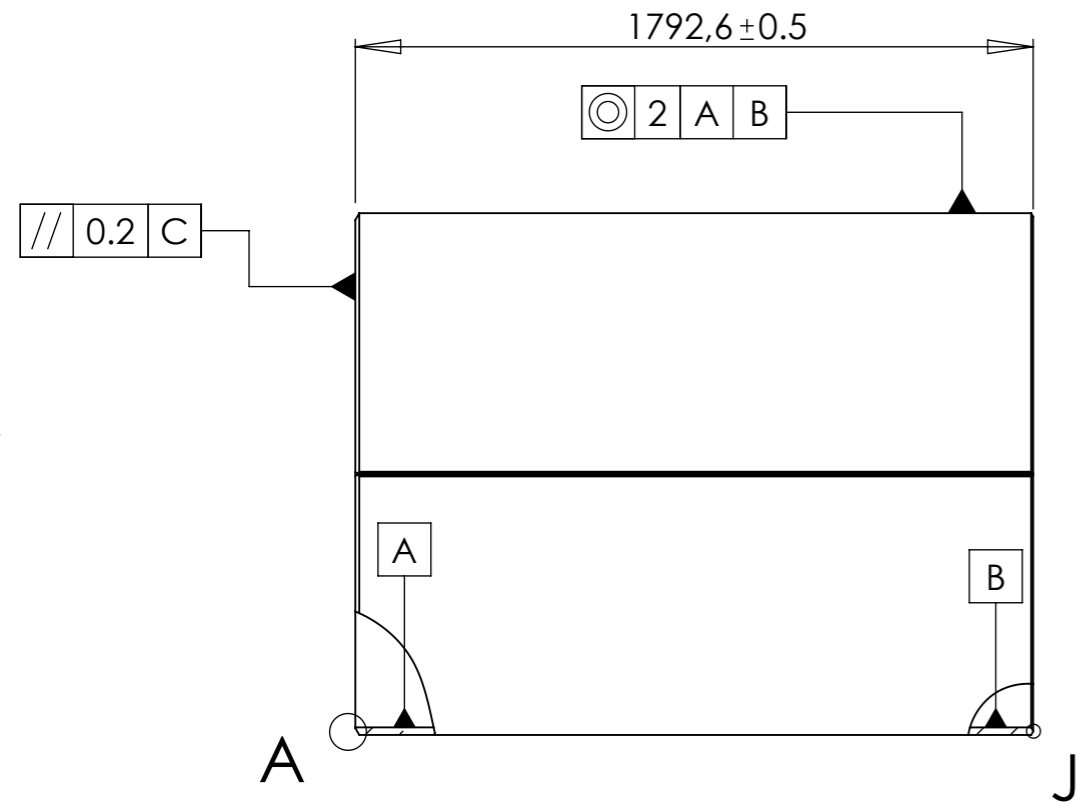

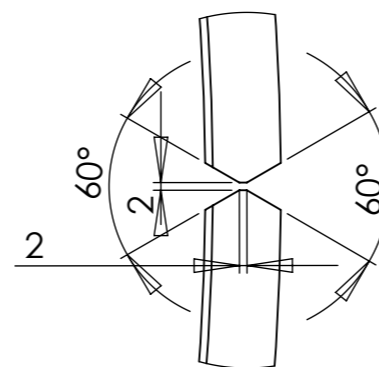
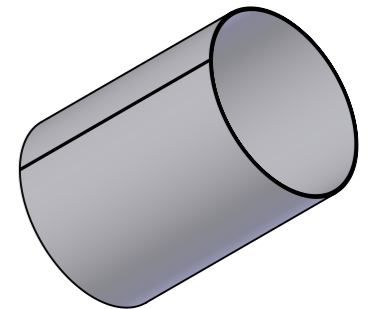

FOR INFORMATION

Porniel



DÉTAIL C
ECHELLE 1 : 2

 ZI du prat Rue des frères Mongolfier F-56000 Vannes Tel(33) 02.97.01.08.80 Fax (33)02.97.01.08.81 EMAIL Contact@sigmaphi.fr	Name	
	Date	21/02/2014
Drawing	M. DELBECQ	
Checked		
Approved		
MATERIAL:	304L (X2CrNi18-9)	
Trait.:		
Roughness :		
Tol Gen	±2	
Supplier:		
Weight:	1203.48 Kg	
	0.00	
	File name:317111-JLA-703-042	
DWG NO.	317111-JLA-703-042	
	Rev:	B
This drawing may not be used without special licence or authorisation express (Law of the 11 march 1957)		
 A3		SCALE:1:50 SHEET 1 OF 1