

Revision and Abstract

Description	Revision	Date
Creation	A	19/04/2013-AS

ABSTRACT

This report presents calculation made by Sigmaphi.

This simulation was carried out with the following parameters:

- Coil mesh 28mm
- Spacer mesh size 28 mm
- Temperature 90°C (Collar temperature 80°C- ambient temperature 22°C= preload temperature 68°C)
- Spacer 2 and 3 copper
- Orientation for conductor material + CTE

Data input of the model

- Collar temperature 90°C (interference fit 90-22=68 K)
- Coil material :
 - Young Modulus X axis : 20Gpa / Poisson ratio 0.31
 - Young Modulus Y axis : 20Gpa / Poisson ratio 0.31
 - Young Modulus Z axis : 100Gpa / Poisson ratio 0.31
- Forces density imported from opera
- Cooldown to 4K

Material

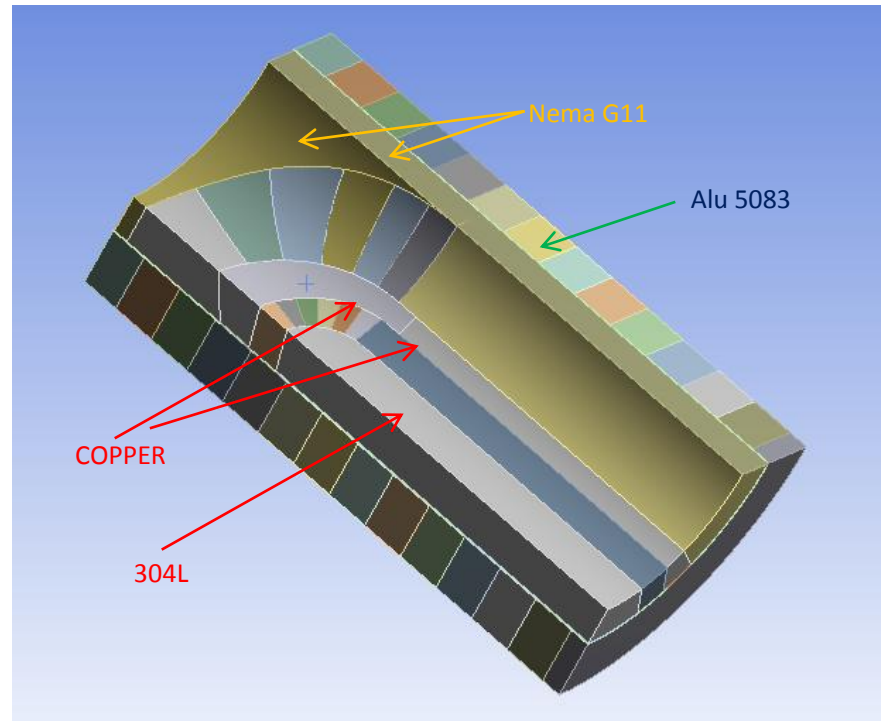

Opera and Ansys axis (Orientation of the model)

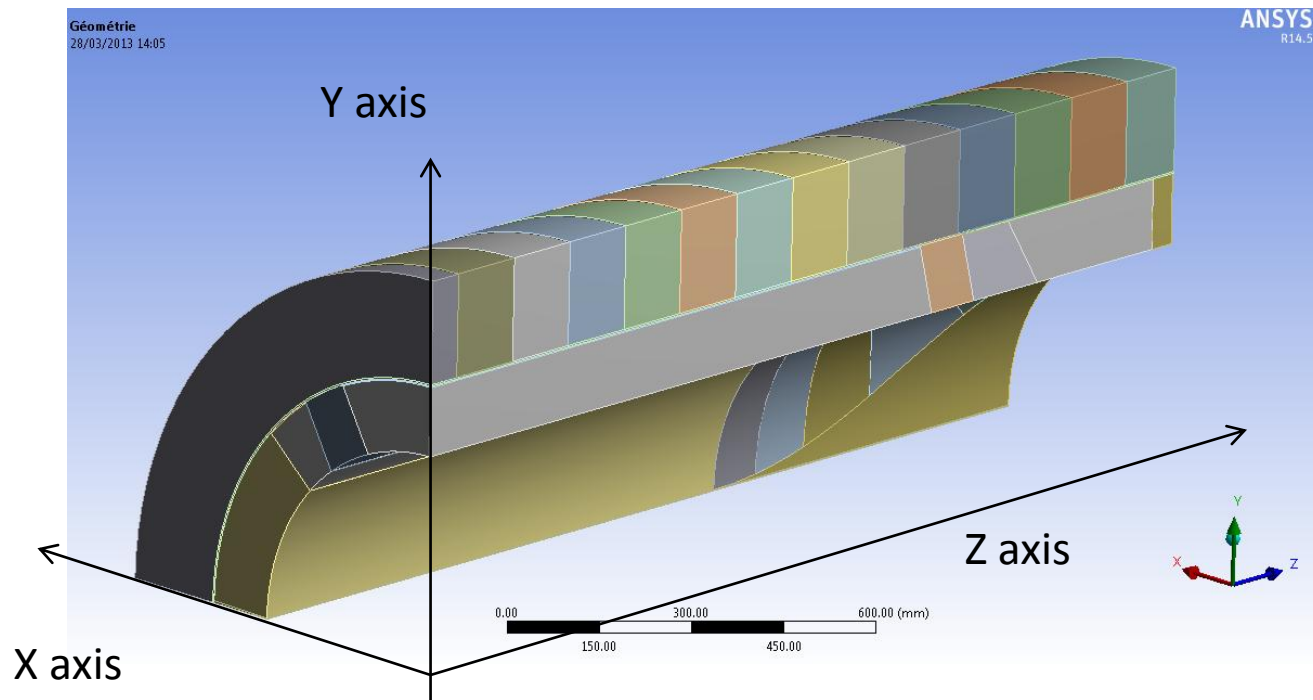

Localization of the forces density centroids

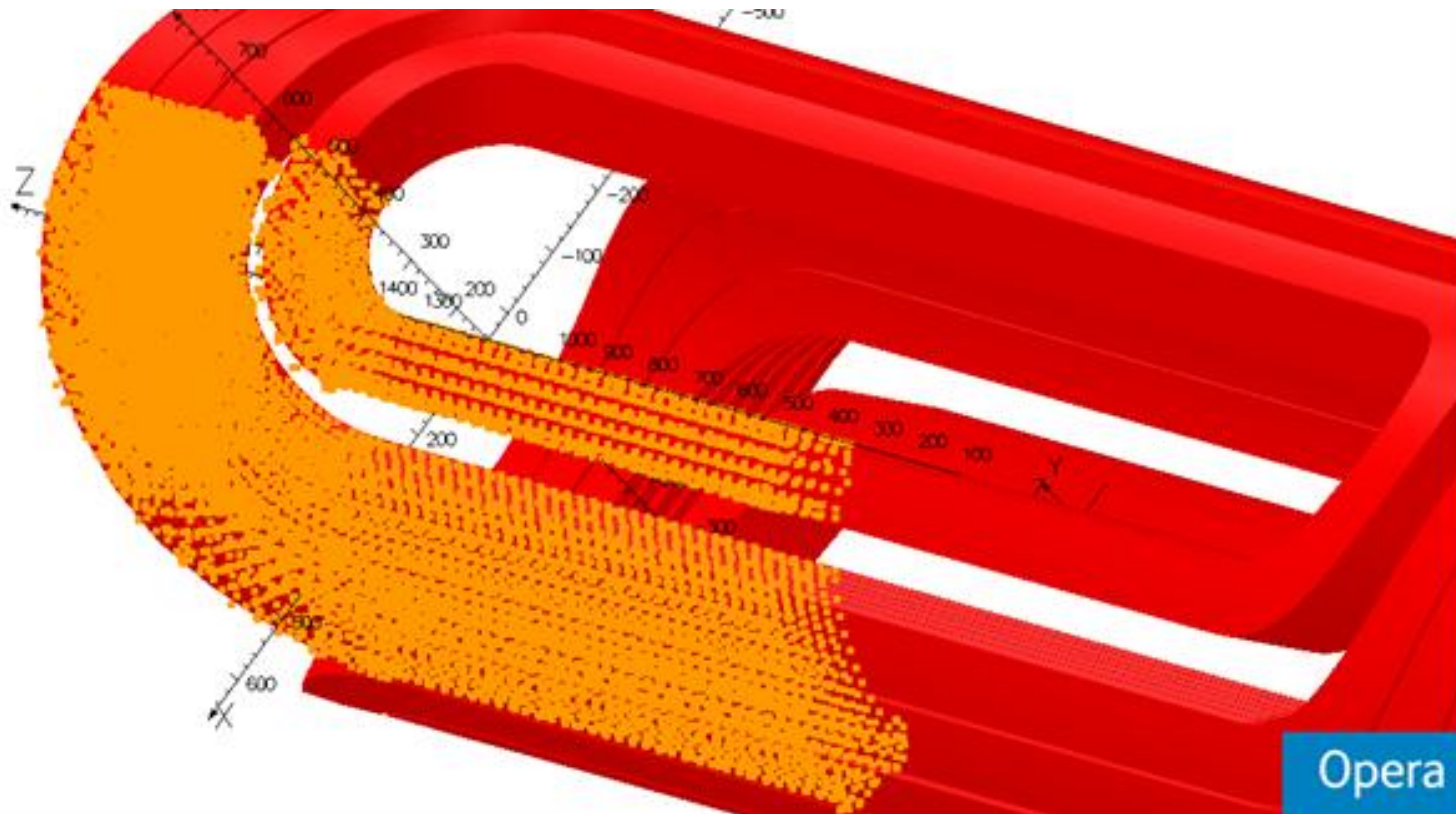

Density distribution of forces in the Opera model

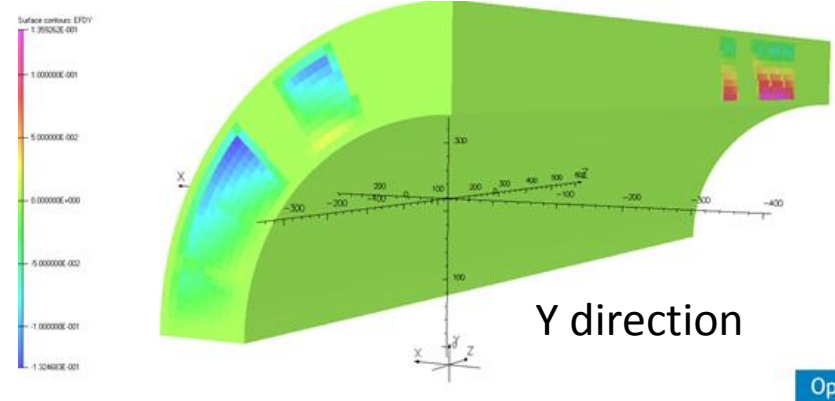
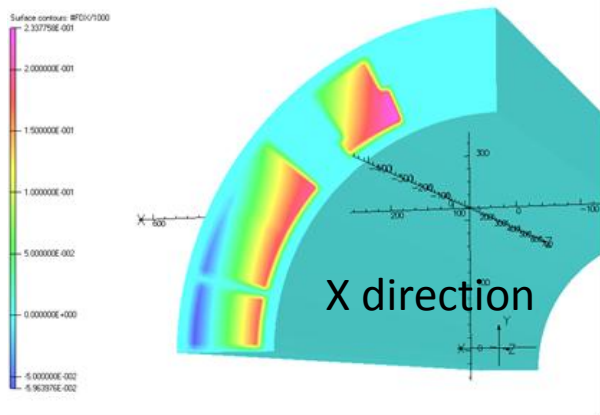

Opera

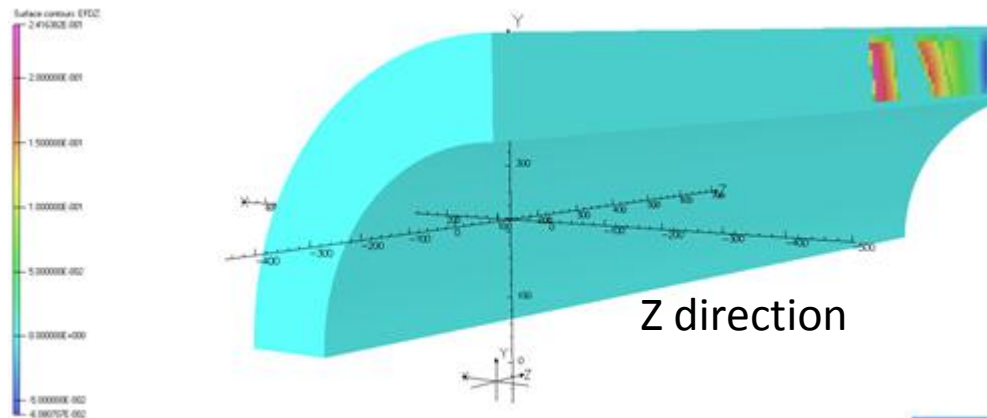

Opera

Density distribution of forces in the Ansys model

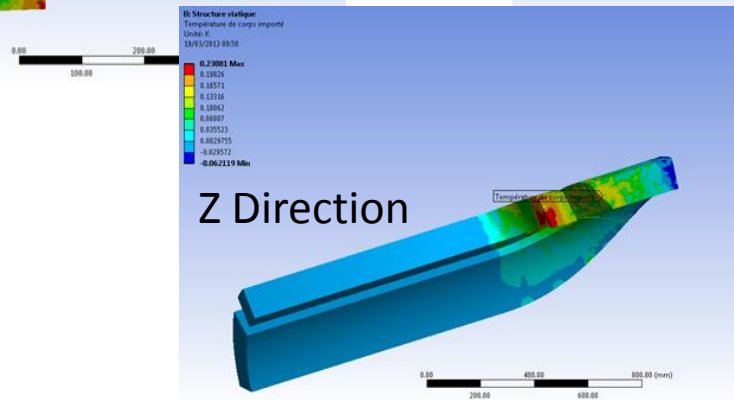
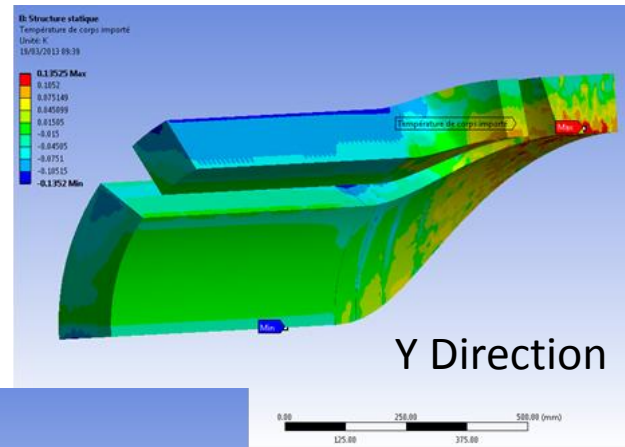
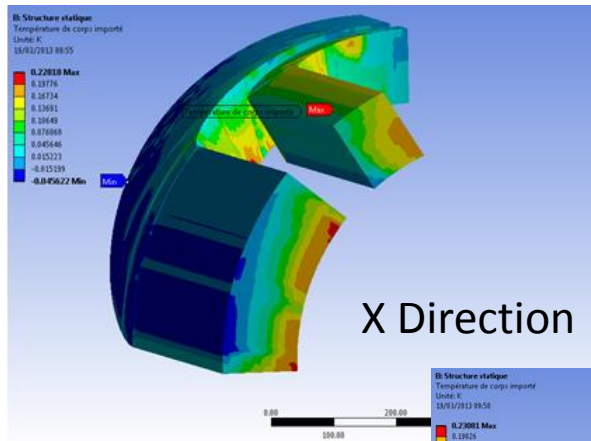

Distorted views of the coil (wired original geometry)

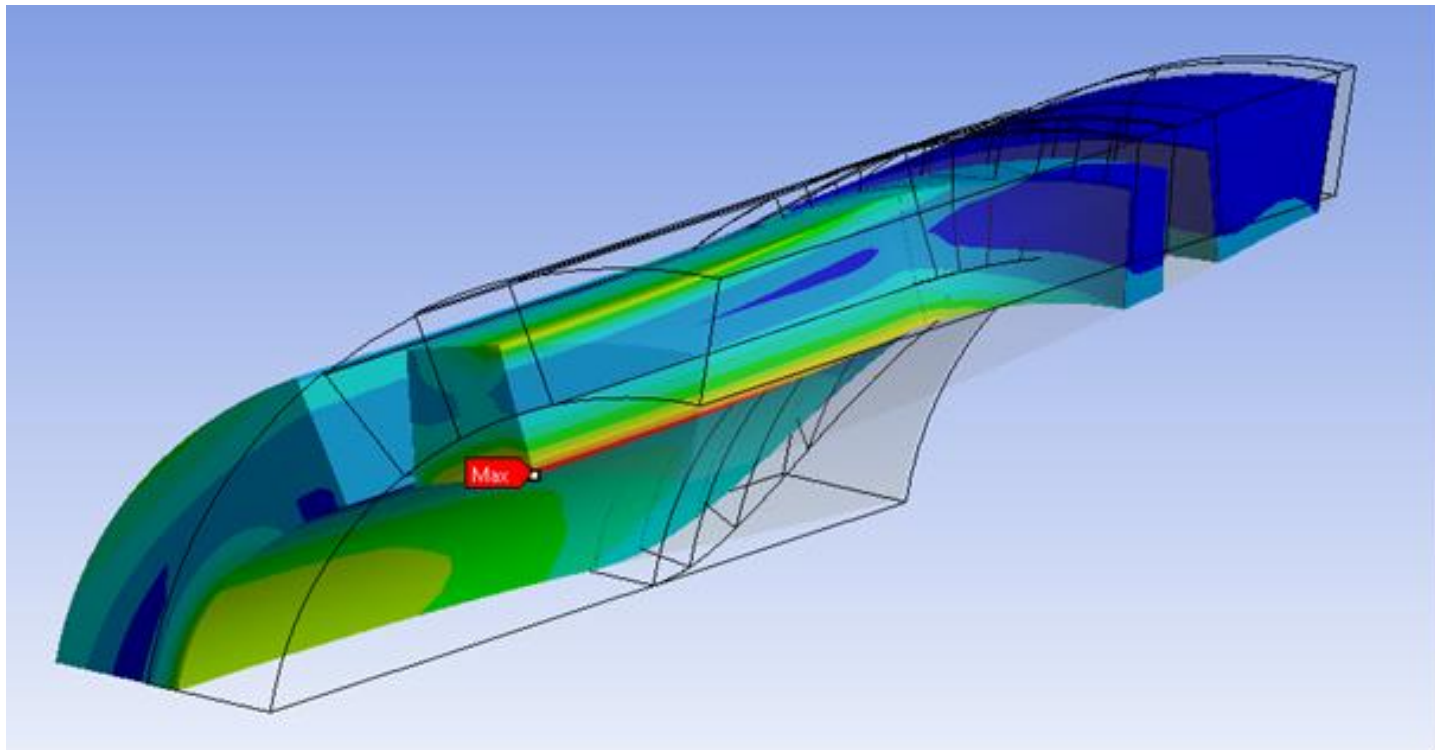

Contacts

Rugueux - face_inter_isolation à face_ext_coils

19/04/2013 18:51

- A** Lié totalement - face_ext_espaceur1 à face_int_c1
- B** Lié totalement - face_int_espaceur2 à face_ext_c1
- C** Lié totalement - face_int_espaceur3 à face_ext_c1
- D** Lié totalement - face_ext_espaceur2 à face_int_c2
- E** Lié totalement - face_ext_espaceur3 à face_int_c2
- F** Avec frottement - face_int_espaceur4 à face_ext_c2
- G** Avec frottement - face_int_espaceur5 à face_ext_c2
- H** Lié totalement - face_ext_espaceur4 à face_int_espaceur5
- I** Avec frottement - face_inter_collier à face_exter_isolation
- J** Rugueux - face_inter_isolation à face_ext_coils

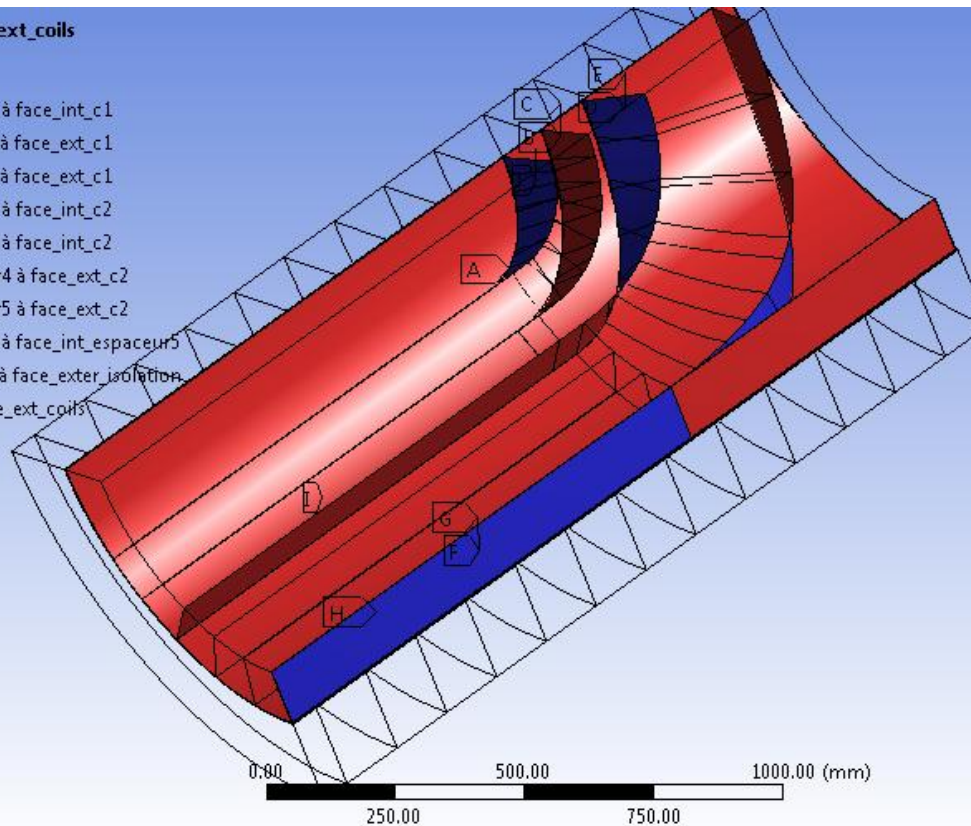

ANSYS
R14.5

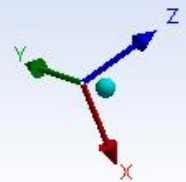

Supports

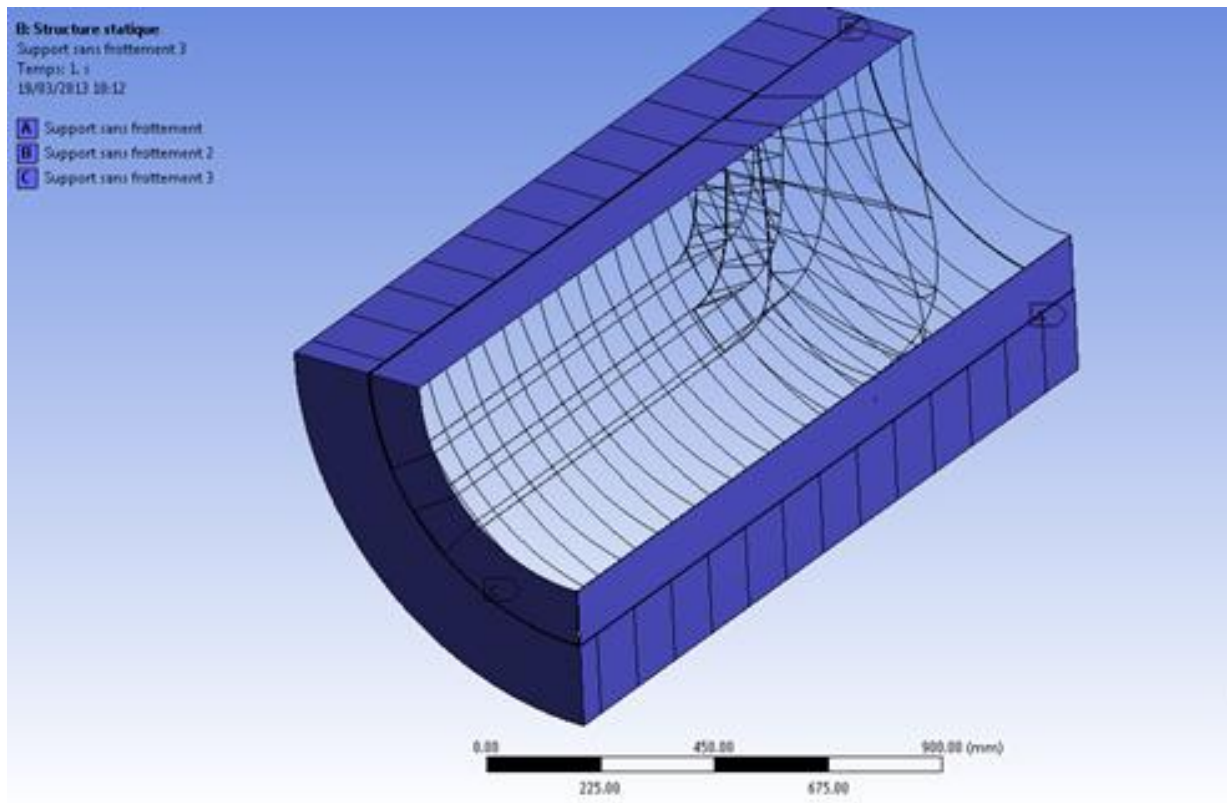

Orientation axis for the orthotropic material. (Coils)

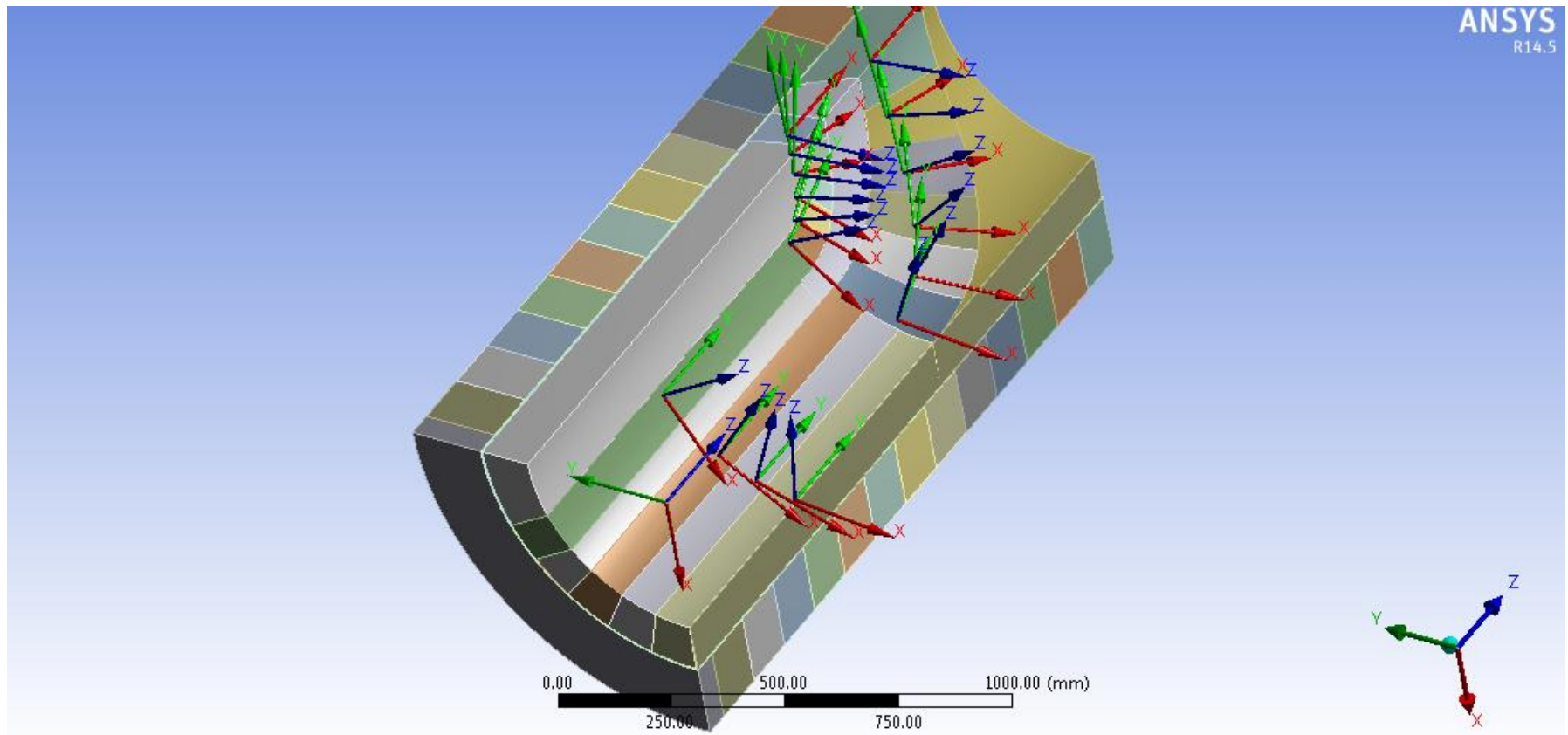

Cooldown 4K– VON MISES STRESS

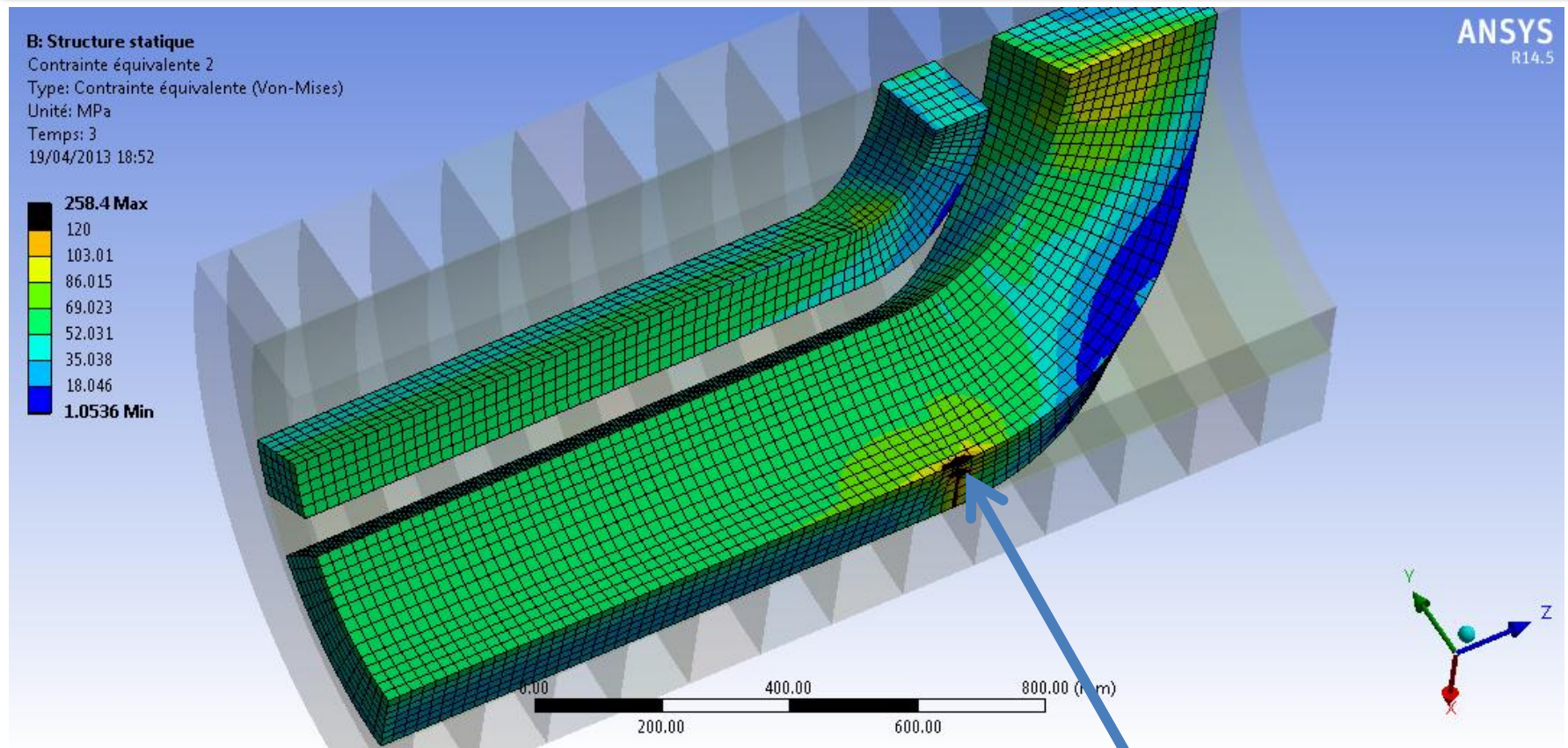

Peak stress not relevant at the sharp edge, artefact due to the bad mesh shape ratio between the coil and the sharp end spacer

Cooldown 4K– CONTACT PRESSURE BETWEEN COLLARS AND COIL

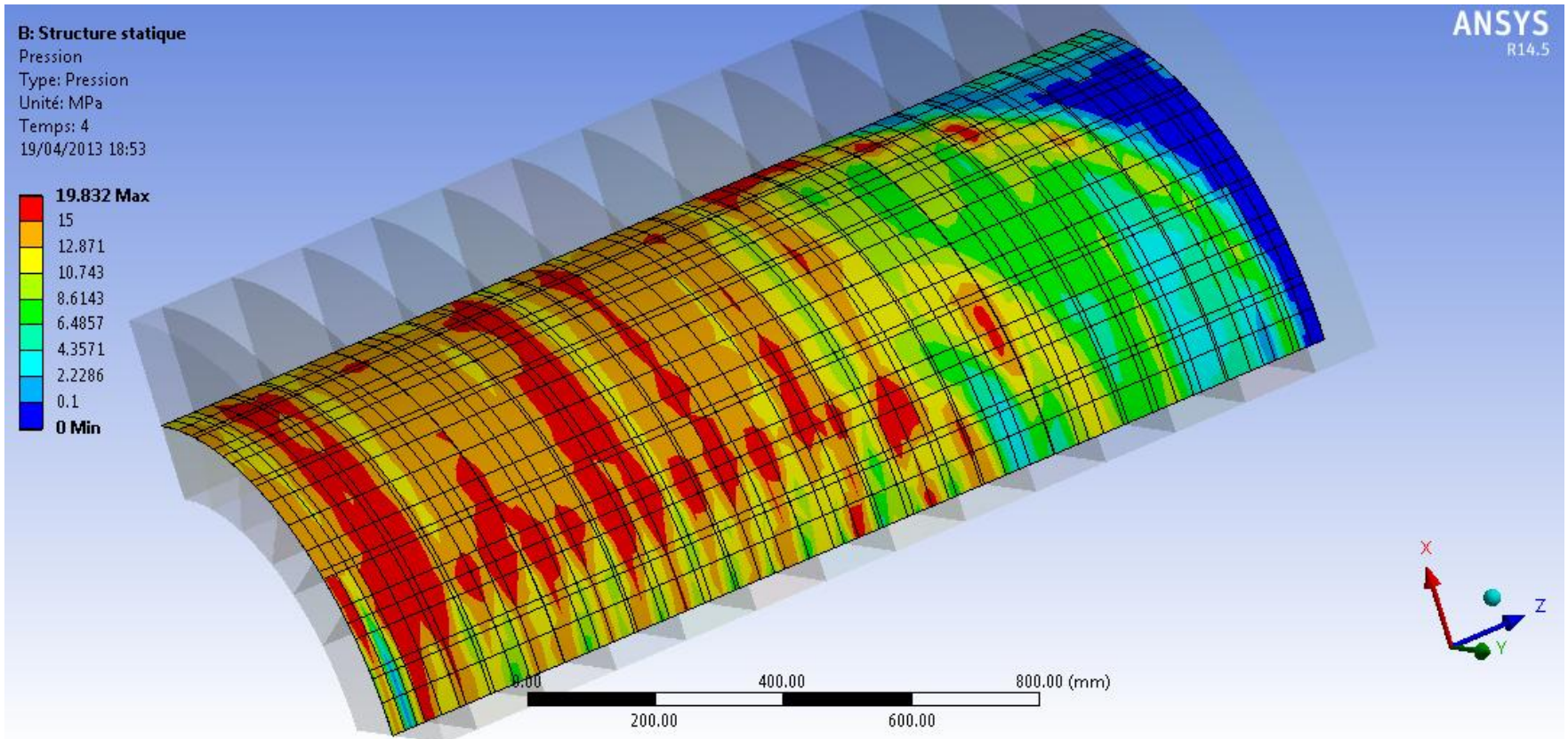

Cooldown 4K– CONTACT PRESSURE BETWEEN CENTRAL SPACER AND COIL

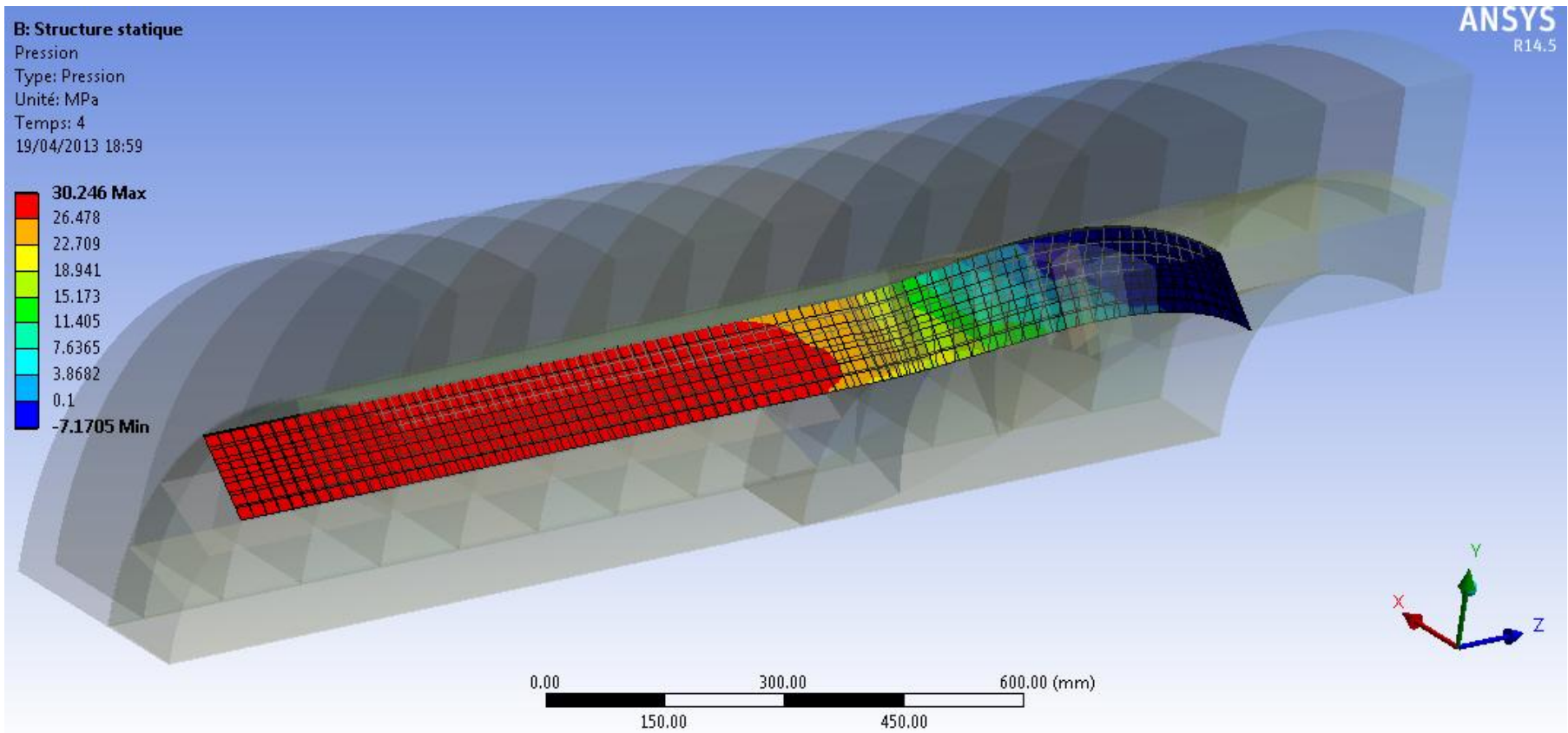

Cooldown 4K + forces– VON MISES STRESS

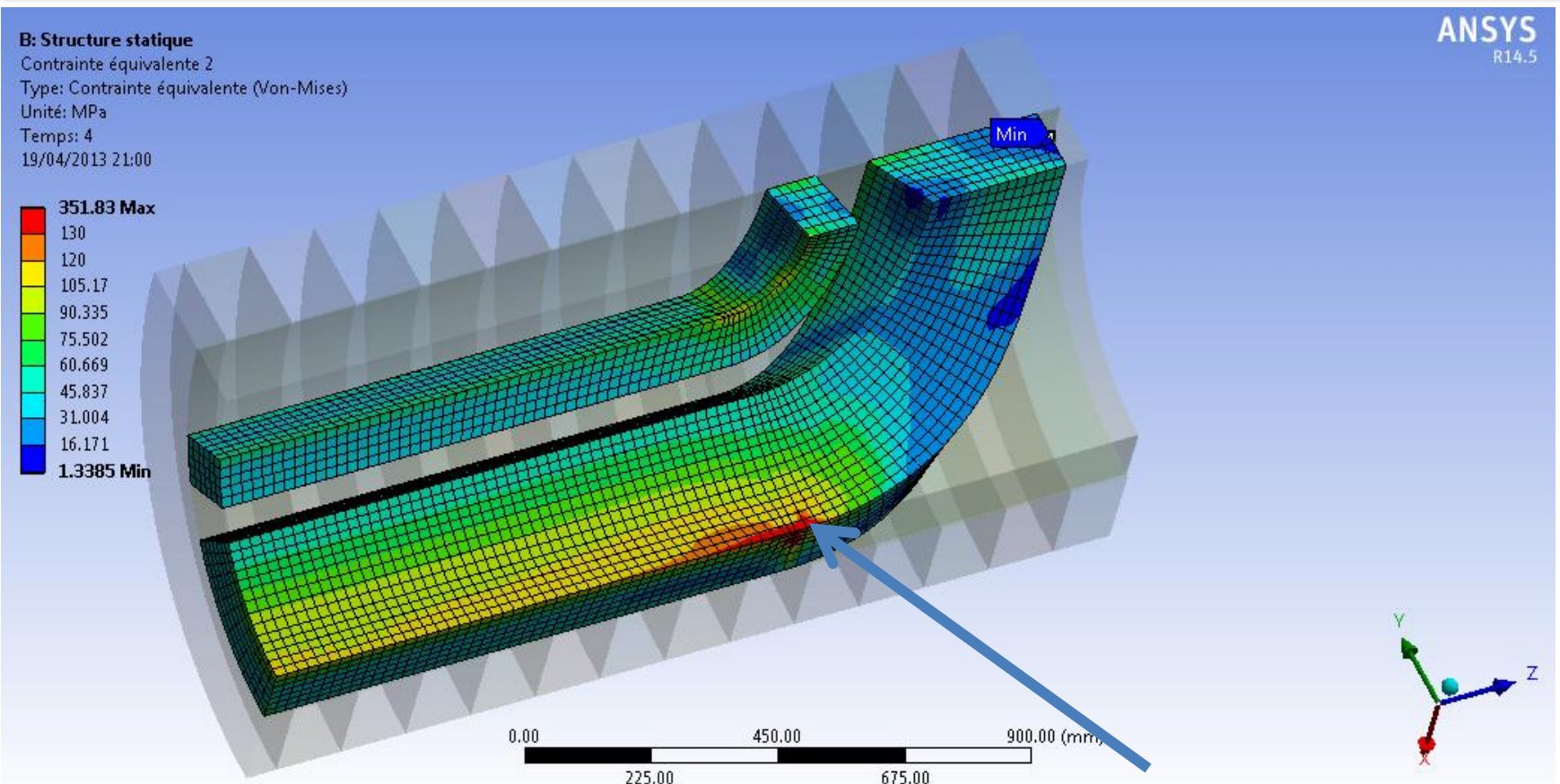

*Peak stress not relevant at the sharp edge,
 artefact due to the bad mesh shape ratio
 between the coil and the sharp end spacer*

Cooldown 4K + forces– Minimum principal stress

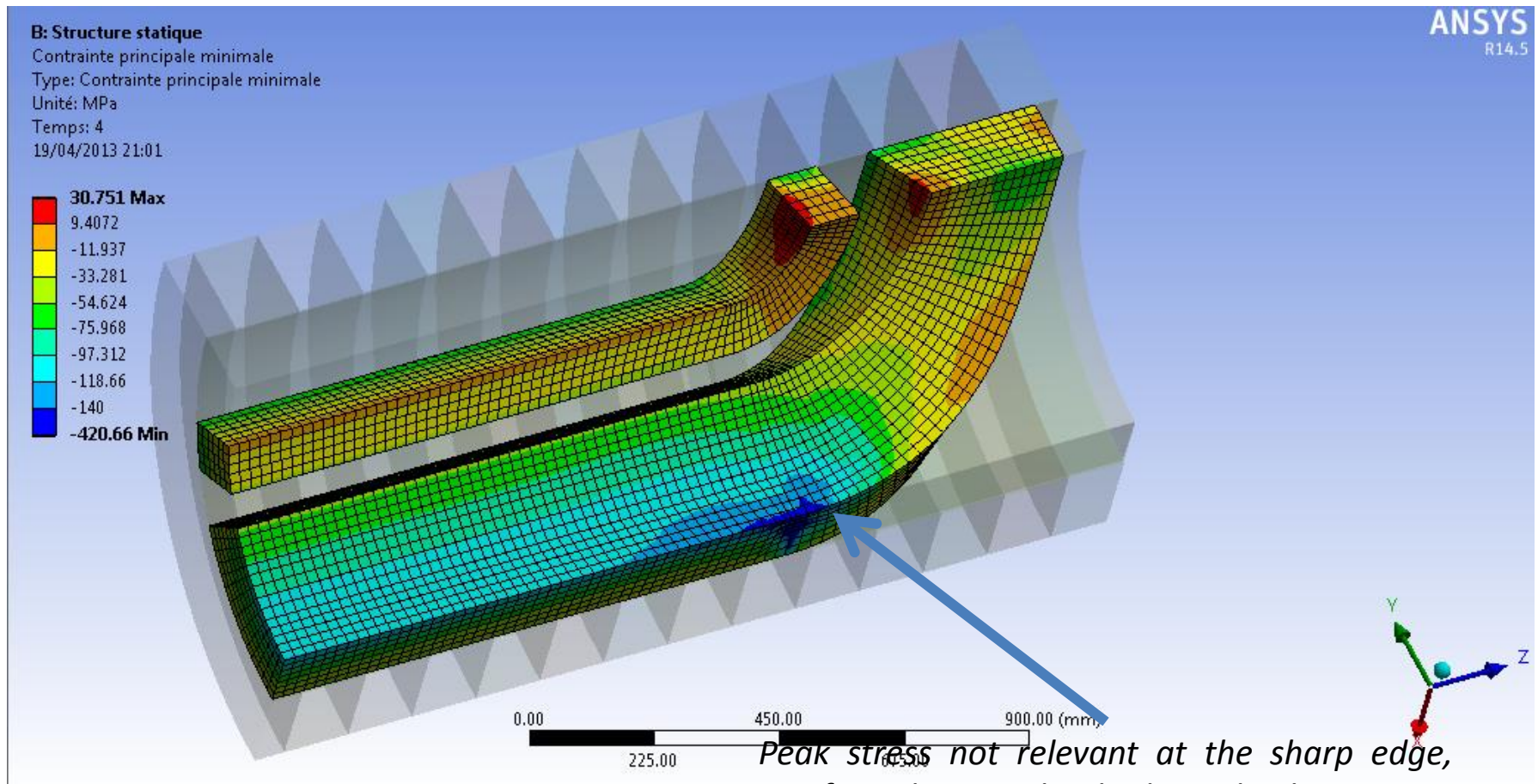

Cooldown 4K + forces– Maximum principal stress

B: Structure statique

Contrainte principale maximale
Type: Contrainte principale maximale
Unité: MPa
Temps: 4
19/04/2013 21:01

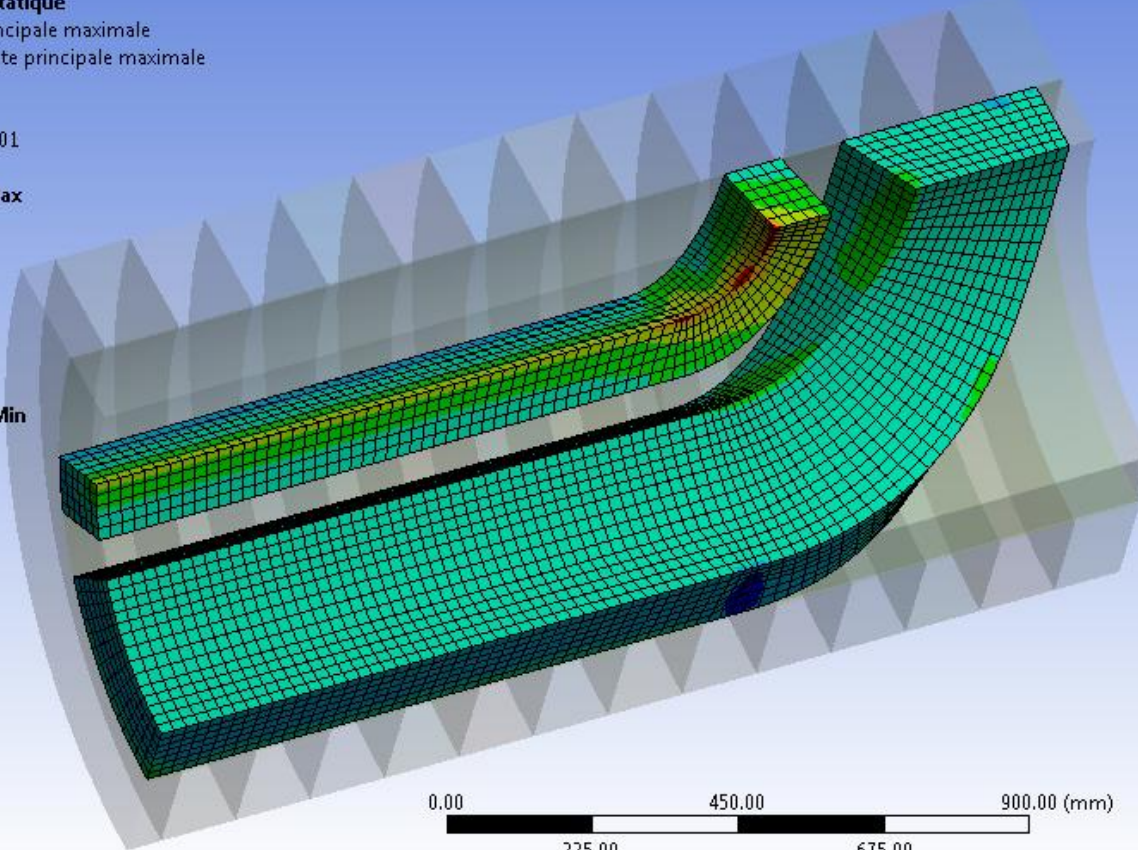
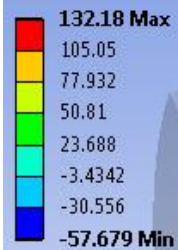

ANSYS
R14.5

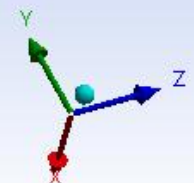

Cooldown 4K + forces– CONTACT PRESSURE BETWEEN COLLARS AND COIL

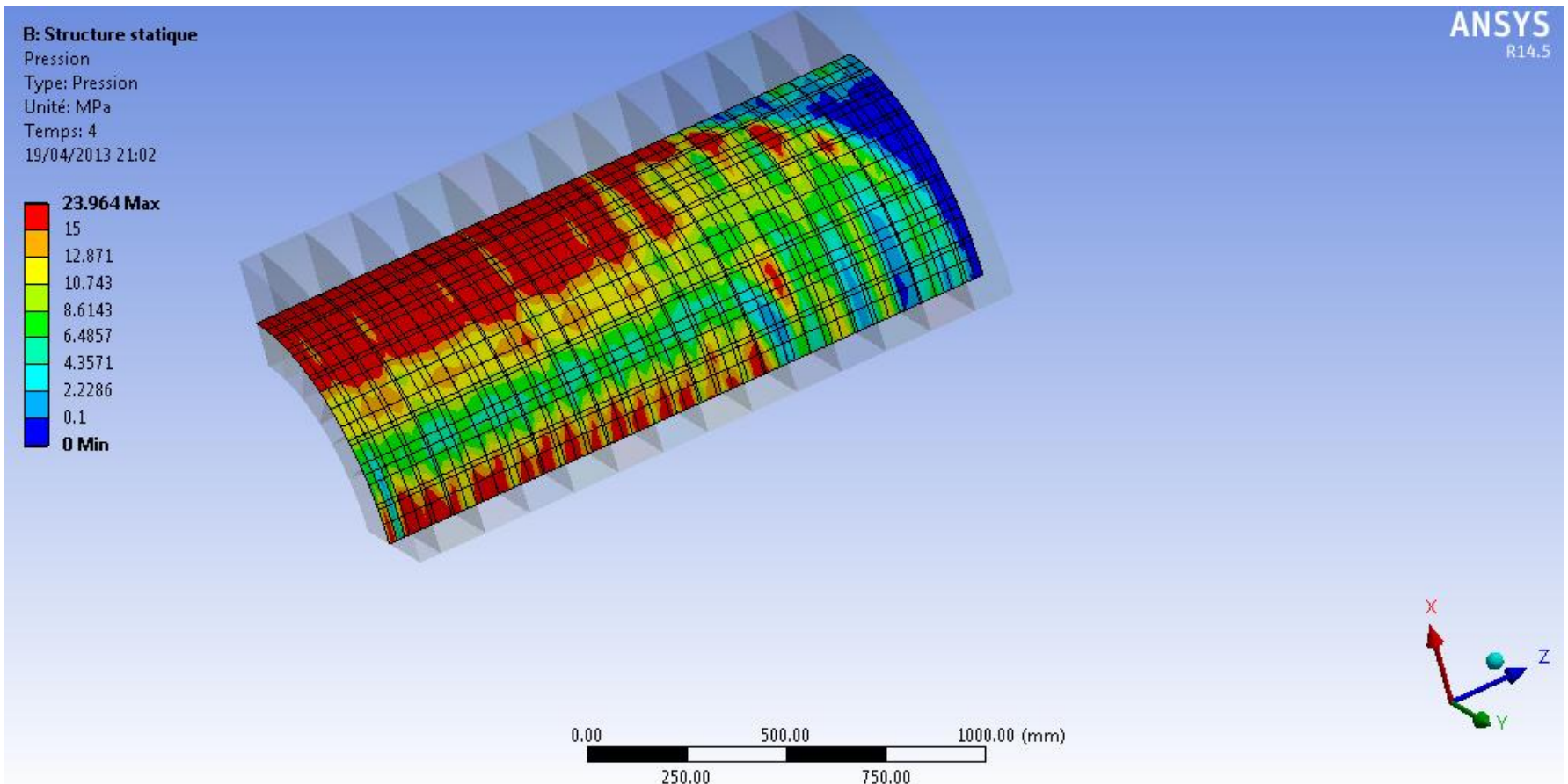

Cooldown 4K + forces – CONTACT PRESSURE BETWEEN CENTRAL SPACER AND COIL

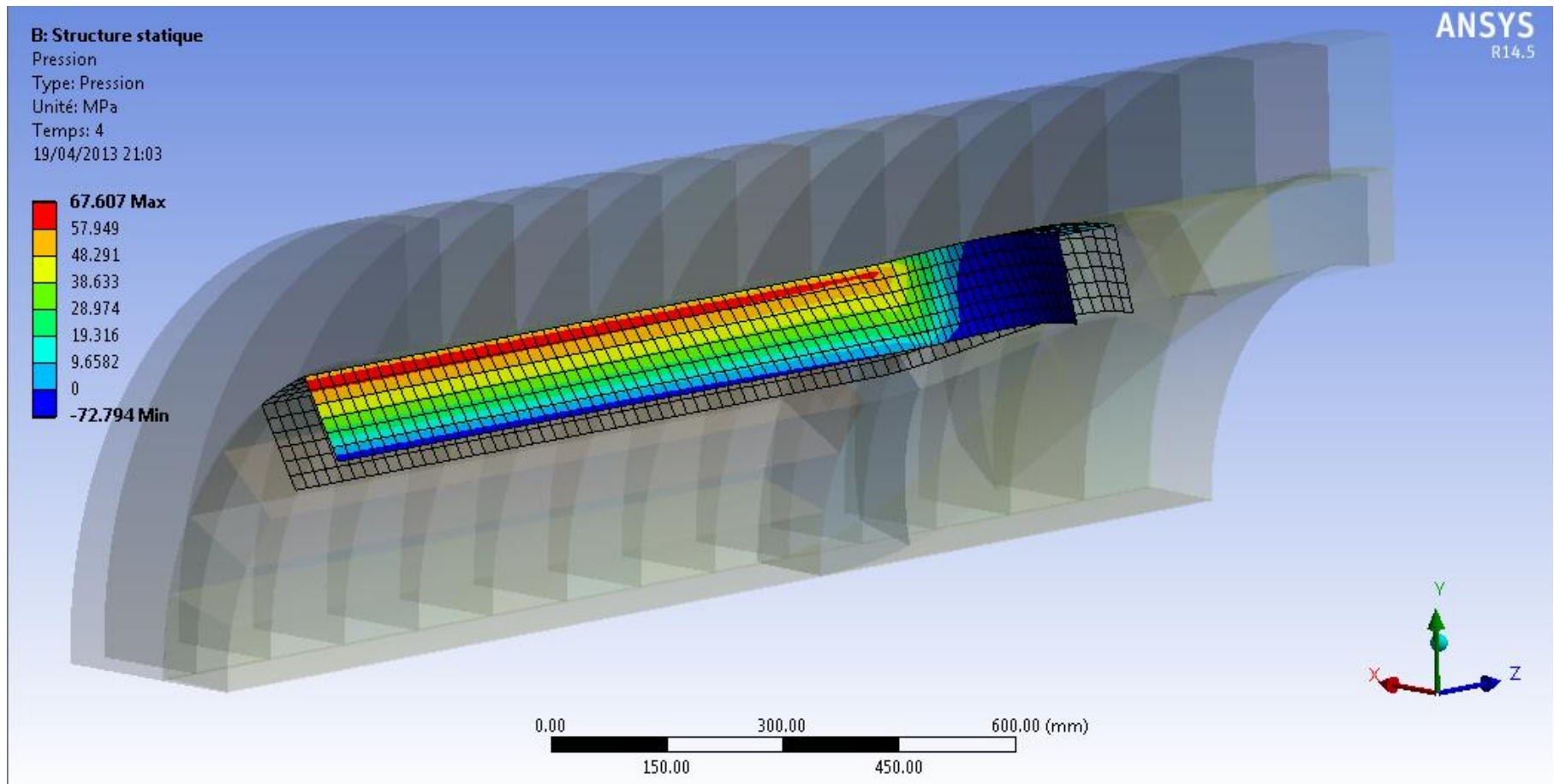

Cooldown 4K + forces– Stress (Von Mises) assembly

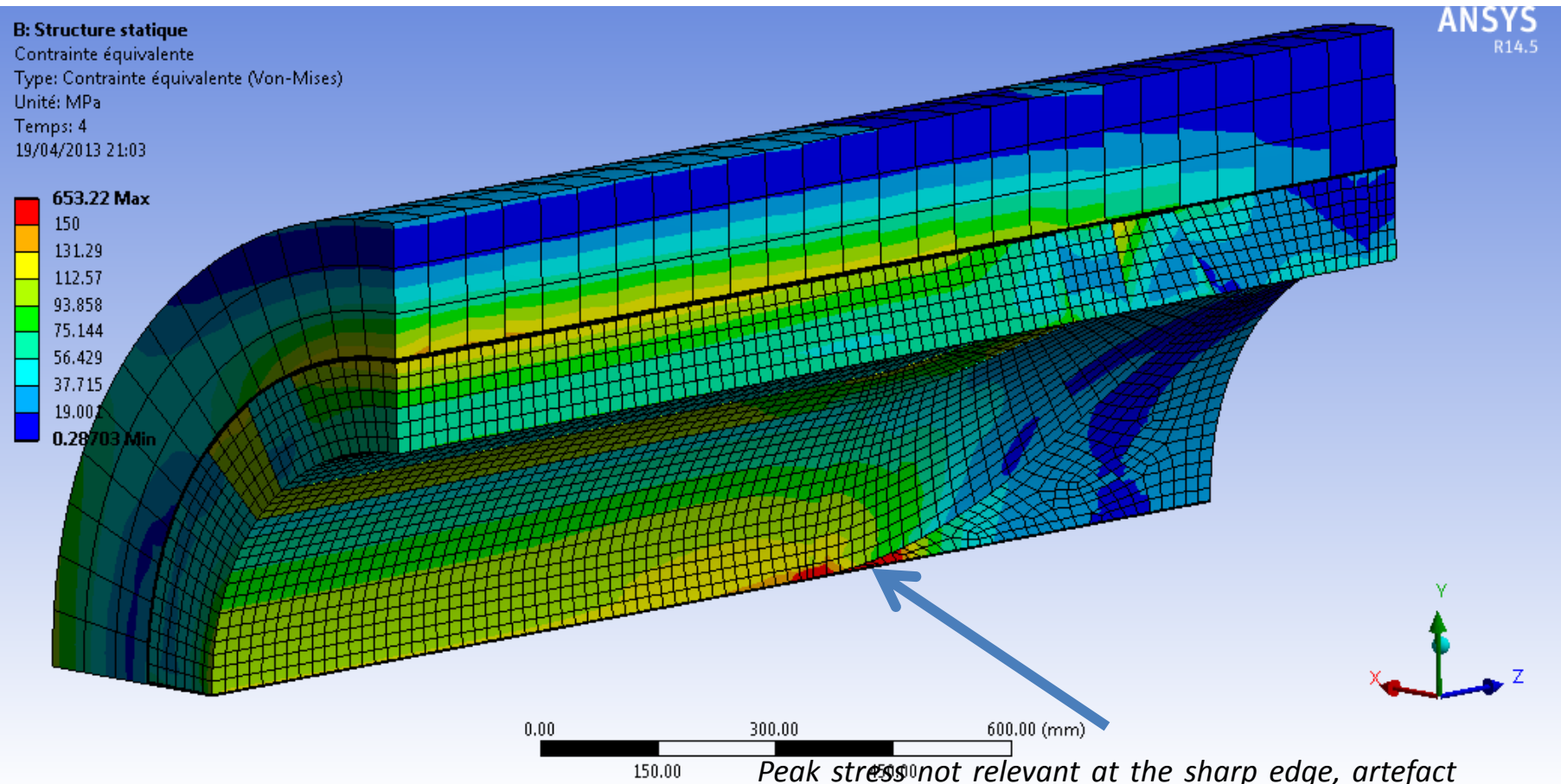

Peak stress not relevant at the sharp edge, artefact due to the bad mesh shape ratio between the coil and the sharp end spacer