

REP	REFERENCE	DESIGNATION	QTY	REV	MATERIAL	MASS (KG)
704-002	318711-JLA-704-002	force ring front end	1	A	alu 5083 [EN-AW 5083]	52.77
704-003	318711-JLA-704-003	standard force ring	24	A	alu 5083 [EN-AW 5083]	52.89
704-004	318711-JLA-704-004	back force ring	1	A	alu 5083 [EN-AW 5083]	59.65
704-006	318711-JLA-704-006	Threaded rod	4	A	A04 [X2CrNi18-9]	4.97
9006	Rondelle - Washer plate M 20-N - Stainless steel	Rondelle - Washer	8		inox / Stainless steel 304L	0.02
9007	Ecrou - Nut H M 20 - Stainless steel	Ecrou hexagonal - Hex nut	4		inox/Stainless steel 304L	0.06
9007	Ecrou - Nut HM M 20 - Stainless steel	Ecrou hexagonal - Hex nut	8		inox/Stainless steel 304L	0.04

REVISIONS				
ZONE	REV.	DESCRIPTION	DATE	AUTHOR
A		CREATION	03/07/2013	M. DELBECQ

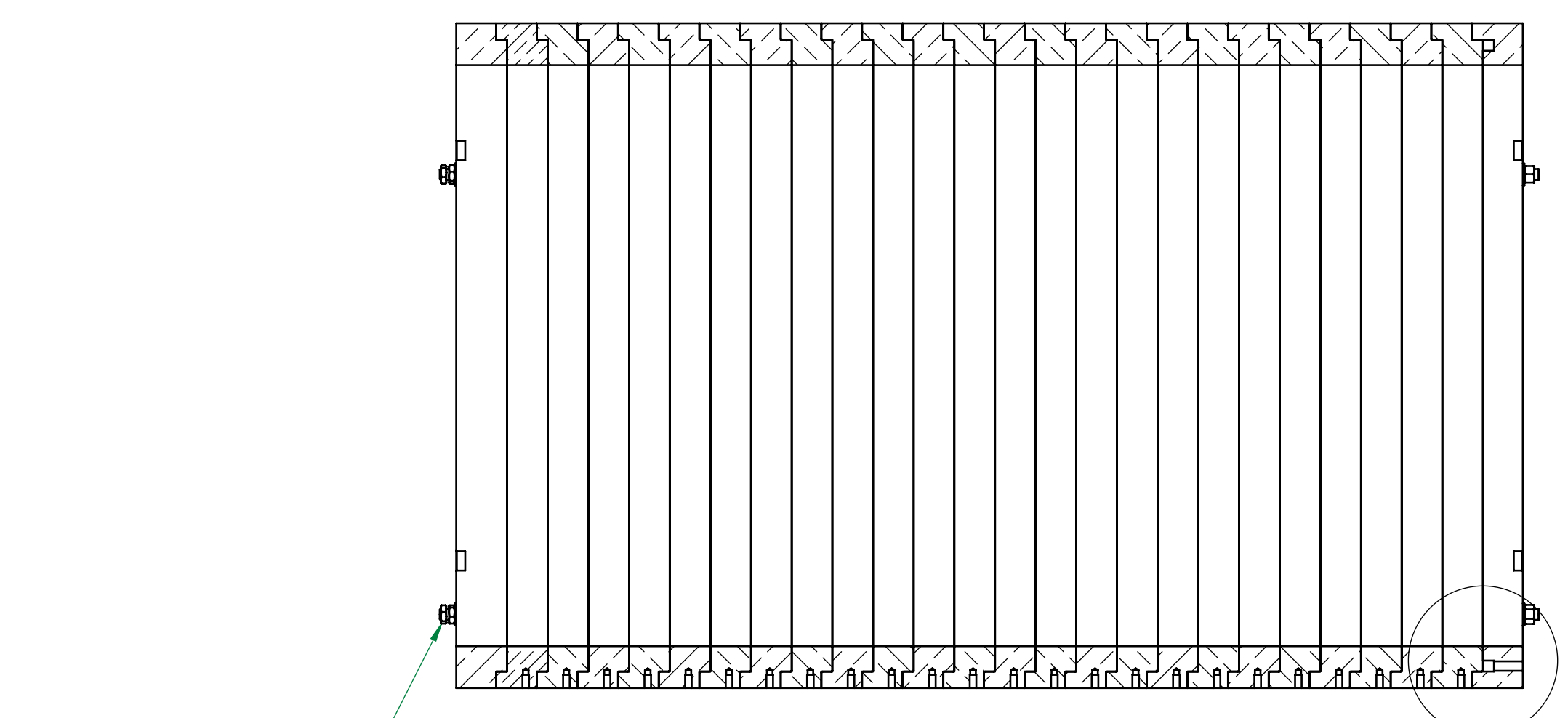

COUPE A-A

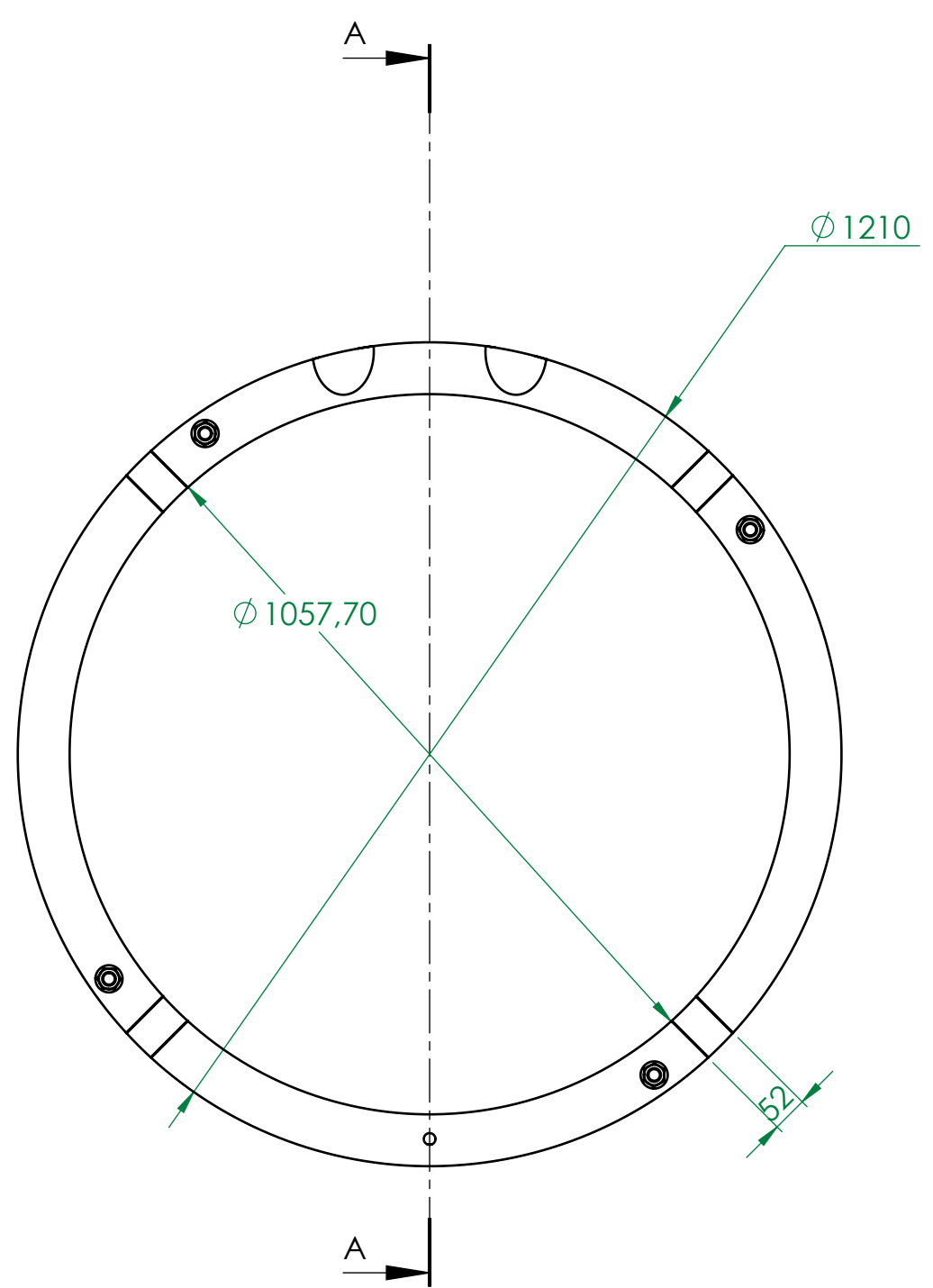
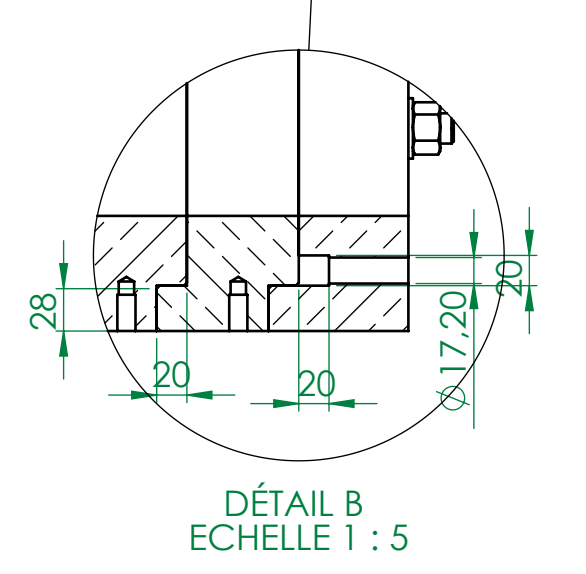

DÉTAIL B
ECHELLE 1 : 5

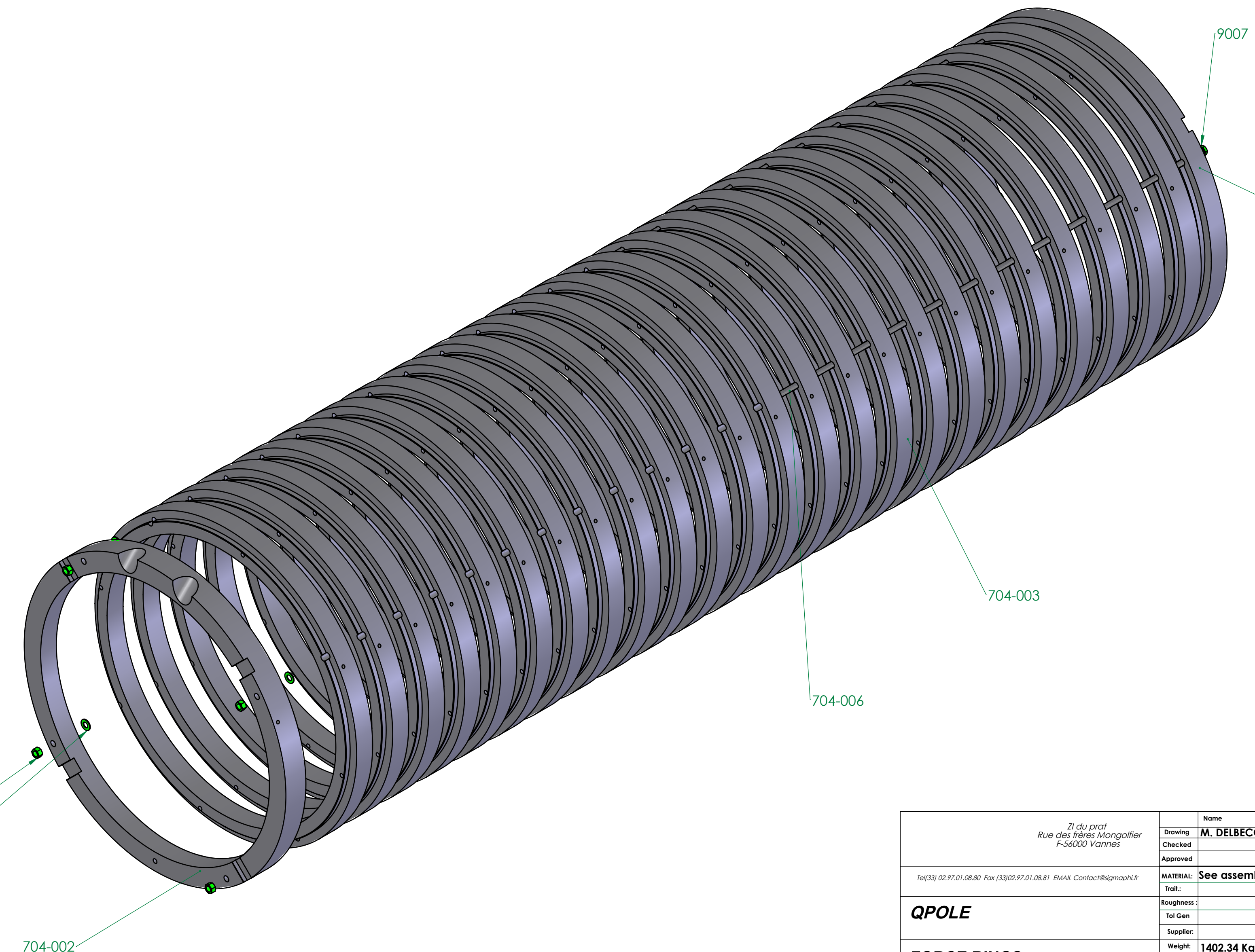
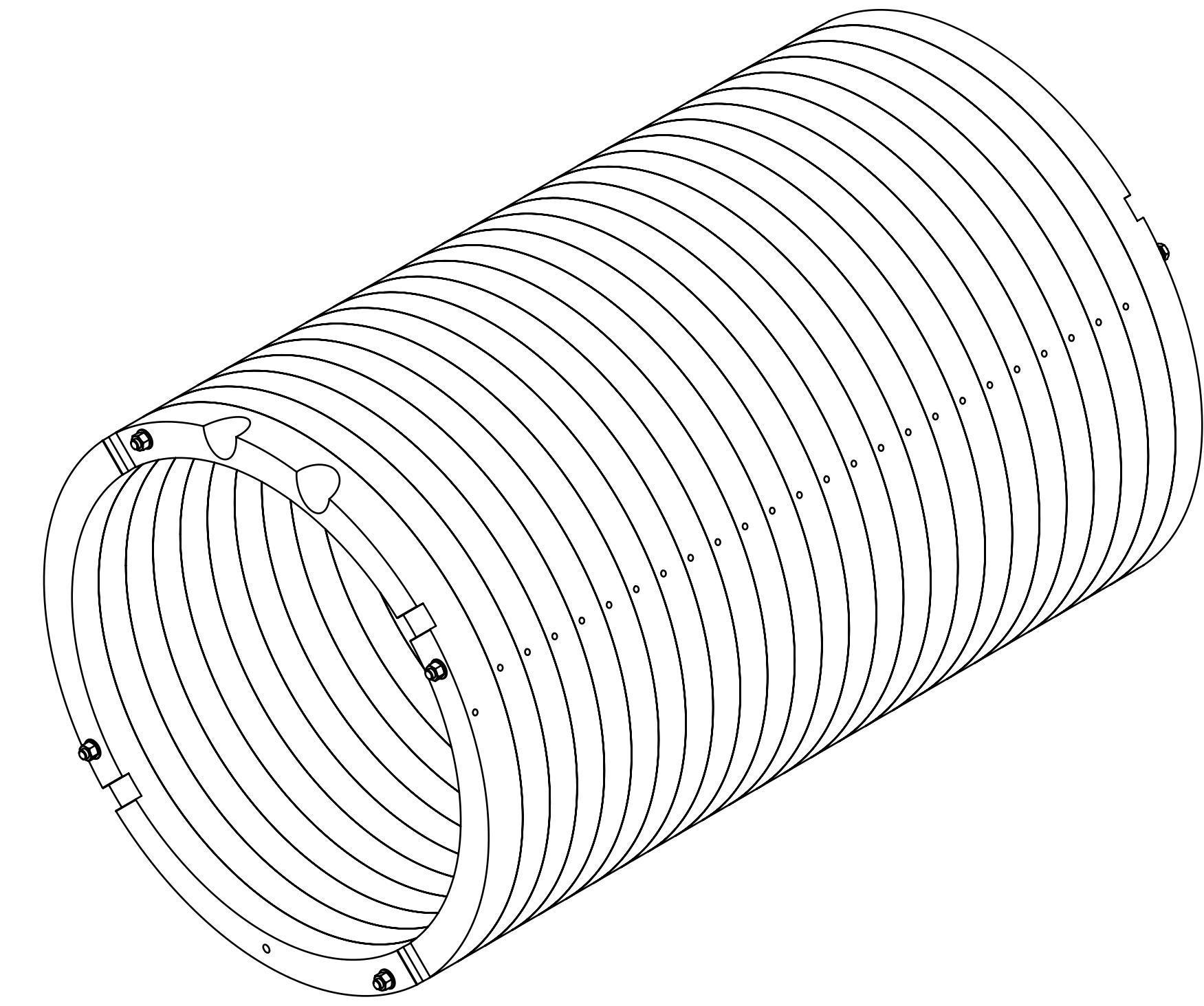
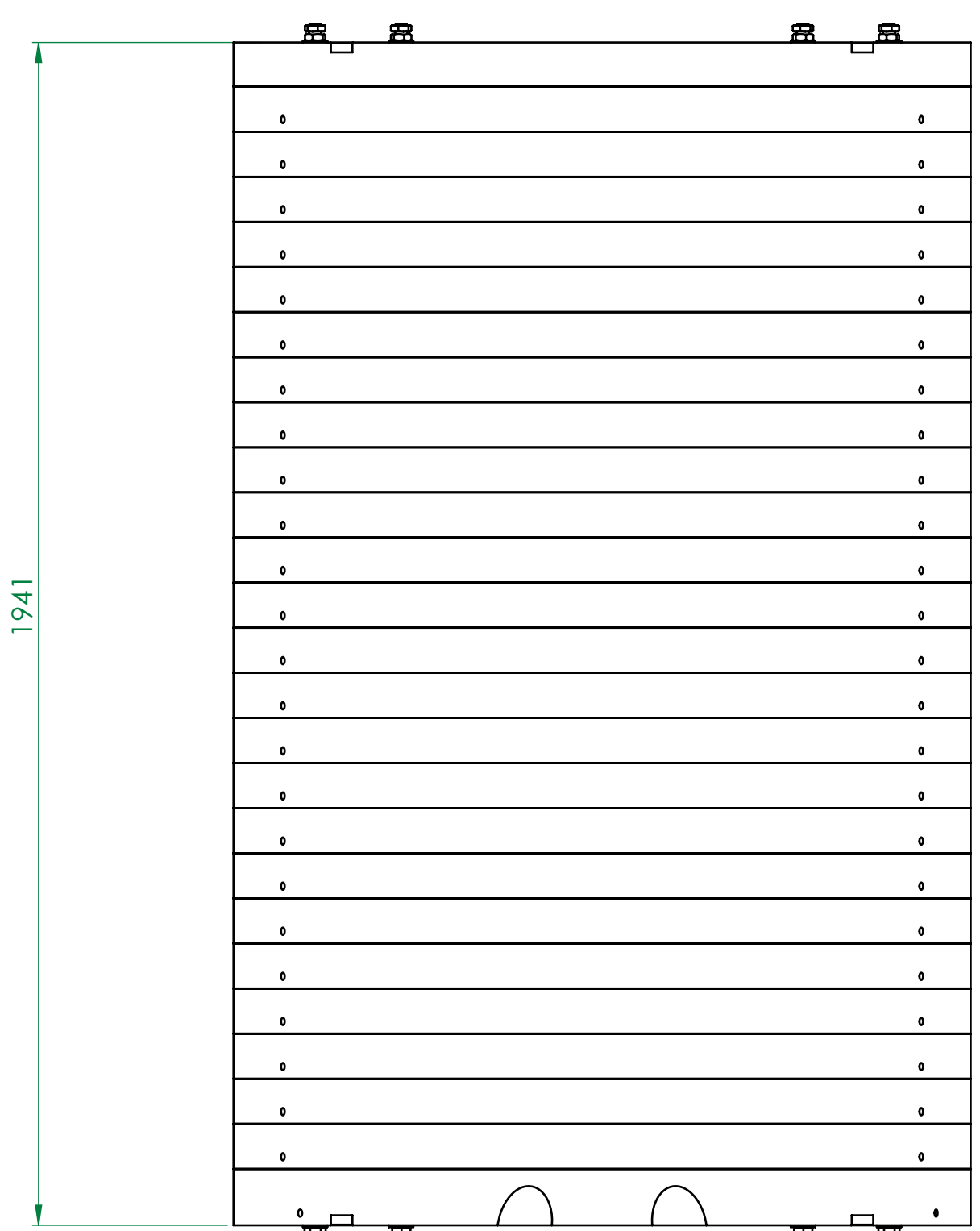

Nom		Date	
Drawn	M. DELBECQ	Drawn	30/09/2013
Checked		Checked	
Approved		Approved	
Material: See assembly		Weight: 1402.34 Kg	
Supplier:		File name: 318711-JLA-704-001	
DWG No: 318711-JLA-704-001		Scale: A	
This drawing may not be used without explicit approval of authorisation engineer. Date of the 11 March 1997			