

REVISIONS				
ZONE	REV.	DESCRIPTION	DATE	AUTHOR
	A	CREATION	03/07/2013	M. DELBECQ

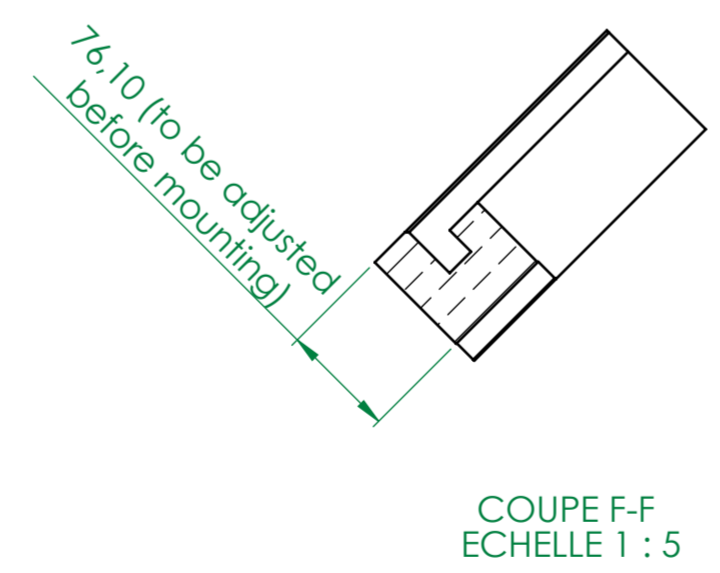
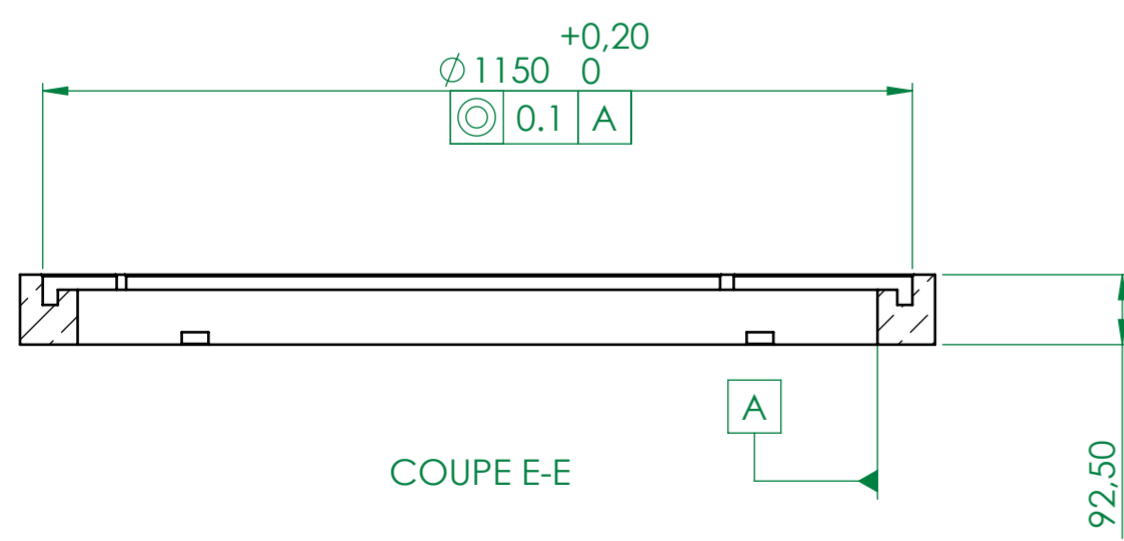
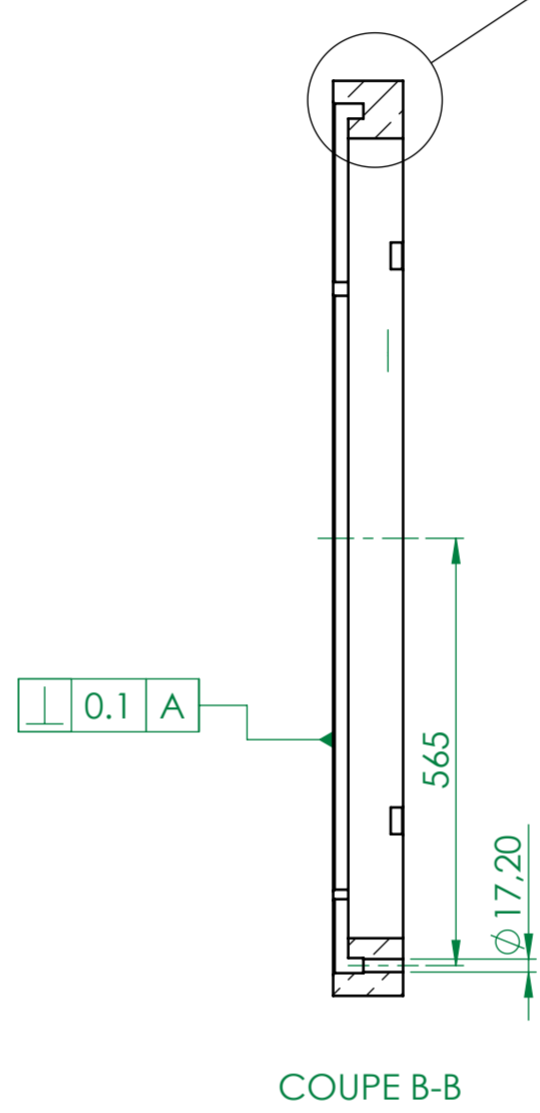
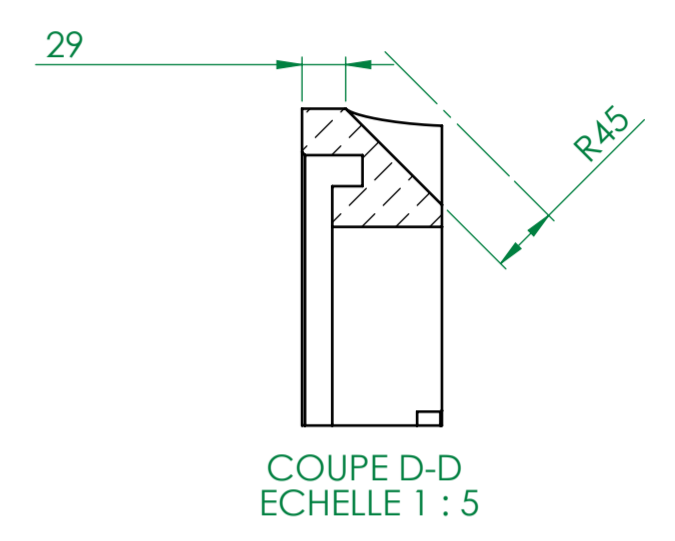
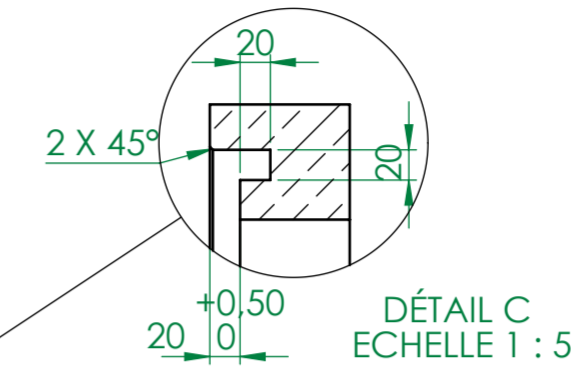
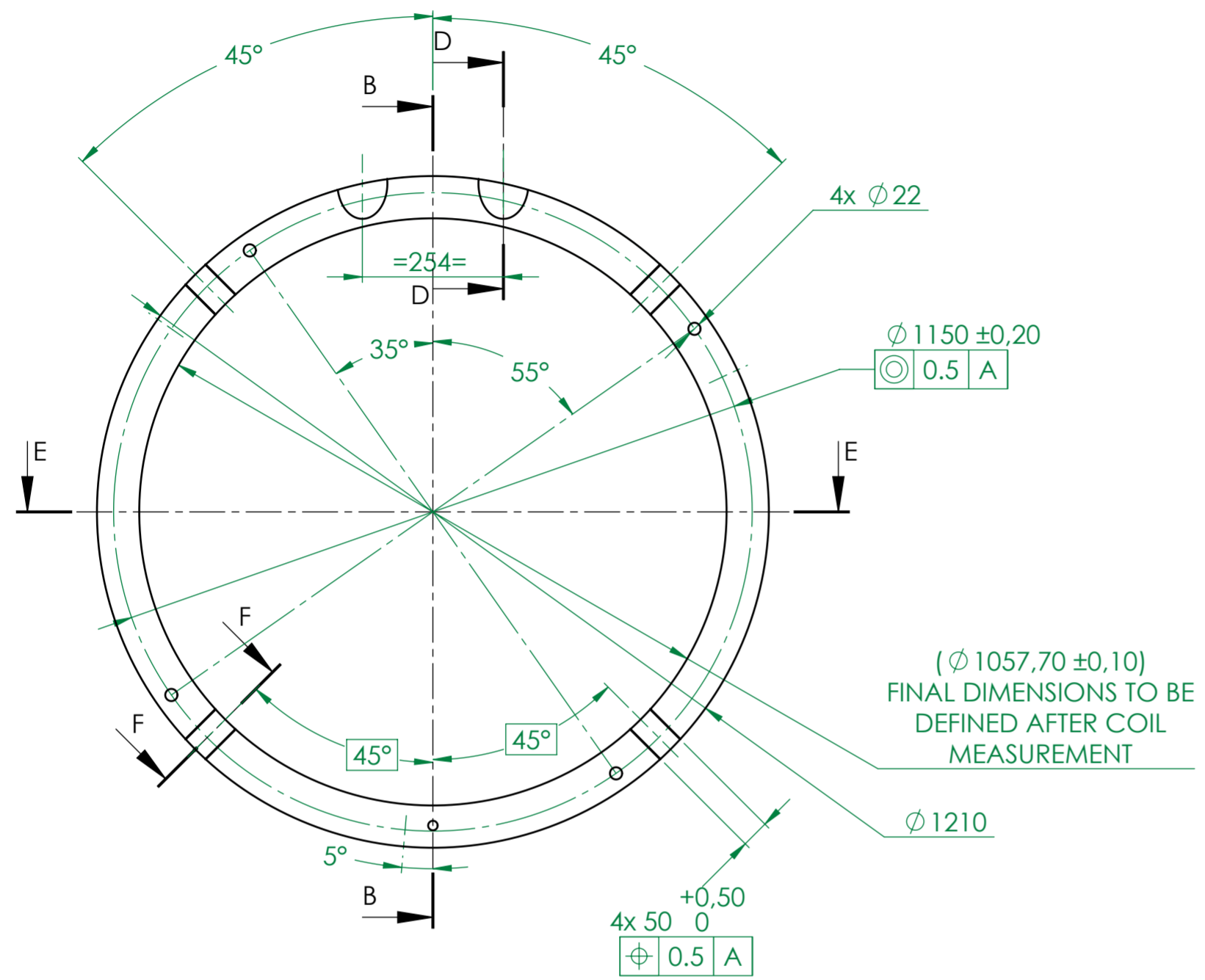
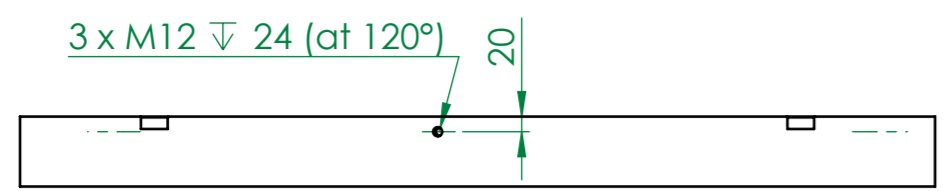

NOTE:  
 State of delivery: H12  
 Anodization thickness ≥ 40 μm  
 Insulation voltage : ≥ 1000 V dc

 <b>SIGMAPHI</b> z du port Rue des frères Mongollier F-56000 Vannes Tel(33) 02.97.01.08.80 Fax (33)02.97.01.08.81 EMAIL Contact@sigmaphi.fr	Name	M. DELBECQ	Date	26/09/2013	
	Drawing	M. DELBECQ			
	Checked				
	Approved				
MATERIAL:	alu 5083 (EN-AW 5083)				
Trait.:	SEE NOTE				
Roughness:					
Tol Gen:	±1				
Supplier:					
Weight:	52.77 Kg				
File name:318711-JLA-704-002					
DWG NO.	<b>318711-JLA-704-002</b>			Rev:	<b>A</b>
This drawing may not be used without special licence or authorisation express (Law of the 11 march 1957)					