

ISO VIEW  
DO NOT SCALE

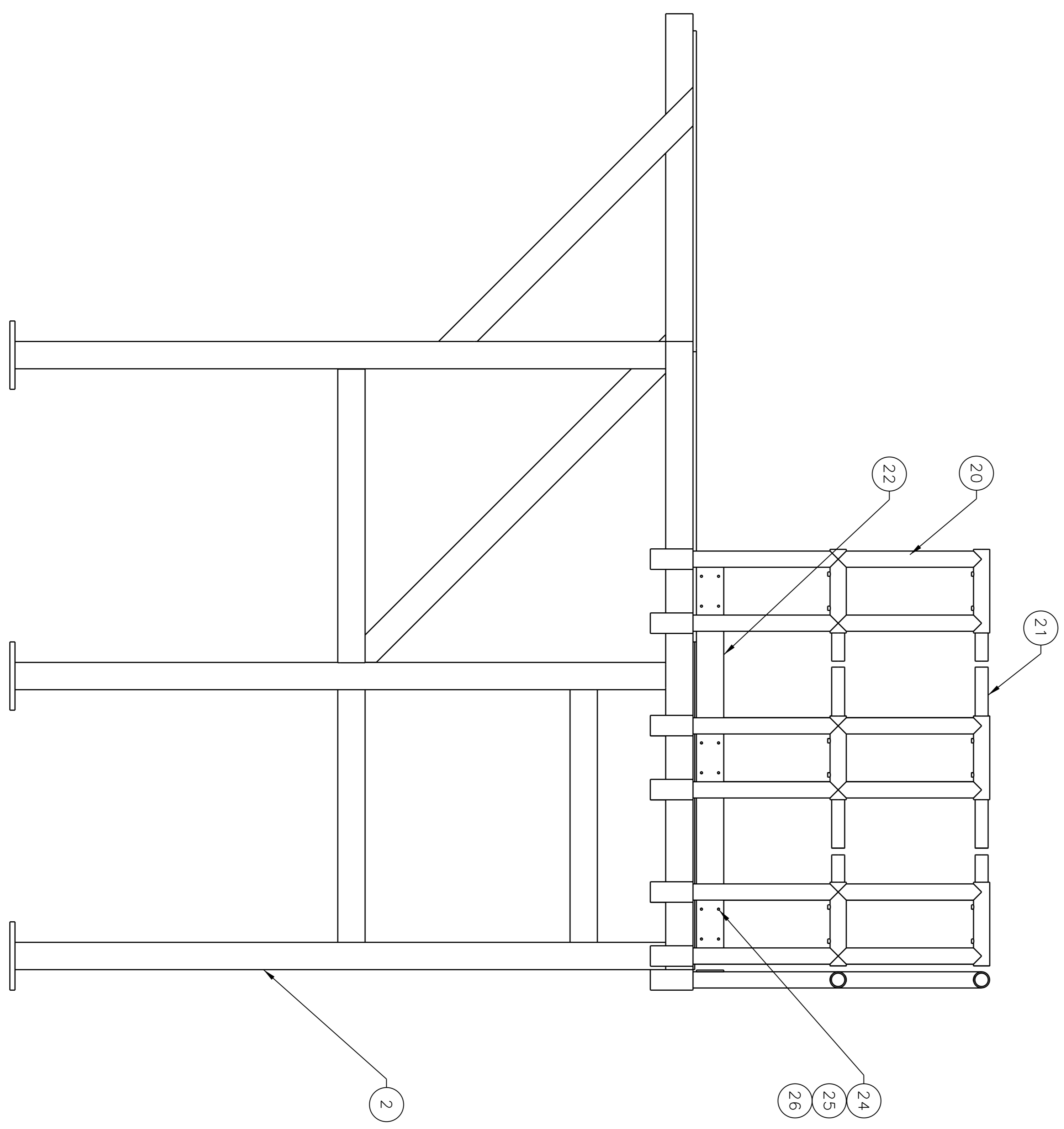

- NOTES:
1. REMOVE ALL SHARP EDGES.
  2. PAINT ALL FERROUS STEEL WITH BLACK RUSTOLEUM.
  3. USE 5/16" FLAT HEAD SCREWS TO SECURE ITEMS 18 AND 19 (DECK PLATES) WITH 12" MAX SPACING. QUANTITY AND PLACEMENT TO BE DETERMINED BY MANUFACTURING.
  4. TO ENSURE ACCURATE SPACING OF ITEMS 17 (HANDRAIL SOCKETS) USE EXISTING SOCKET WELDING FIXTURE (67105-56000-06) WHEN WELDING ITEMS 17 TO SUPPORT STAND.
  5. ALL WELDS TO BE ALL AROUND 1/4 FILLETS UNLESS OTHERWISE NOTED.

12	26	NUT	1/4-20 STANDARD	STAINLESS STEEL	-
12	25	WASHER	1/4 STANDARD	STAINLESS STEEL	-
12	24	HEX HEAD BOLT	1/4-20 X 1.0 LG	STAINLESS STEEL	-
AR	23	FLAT HEAD CAP SCREW	5/16-18 X 1.00 LG	ALLOY STEEL	-
3	22	67105-5600-05	KICK PLATE	(EXISTING PART) 6061-T6 ALUMINUM	-
14	21	67105-5600-04	SLIDING HANDRAIL	(EXISTING PART) 6061-T6 ALUMINUM	-
8	20	67105-5600-02	HANDRAIL WELDMENT	(EXISTING PART) 6061-T6 ALUMINUM	-
1	19	-19	MAIN DECK	3/8 THK 6061 ALUM DIAMOND HEAD PLATE	-
1	18	-18	SUPPORT DECK	1/2 THK 6061 ALUM PLATE	-
1	17	67105-56000-03	HANDRAIL SOCKET WELDMENT	1018 STEEL	-
1	16	-16	DECK SUPPORT GUSSET, SHORT	4 X 4 X 1/4 ALLOY STEEL TUBING	-
1	15	-15	DECK SUPPORT GUSSET, LONG	4 X 4 X 1/4 ALLOY STEEL TUBING	-
1	14	-14	EXTENSION VERTICAL GUSSET	4 X 4 X 1/4 WALL TUBING	-
1	13	-13	EXTENSION HORIZONTAL GUSSET	4 X 4 X 1/4 WALL TUBING	-
2	12	-12	EXTENSION CROSS BEAM	4 X 4 X 1/4 WALL TUBING	-
1	11	-11	MID HORIZONTAL SUPPORT BEAM	4 X 4 X 1/4 WALL TUBING	-
1	10	-10	MID STRUCTURE GUSSET	4 X 4 X 1/4 WALL TUBING	-
2	9	-09	HORIZONTAL SUPPORT BEAM, SHORT	4 X 4 X 1/4 WALL TUBING	-
5	8	-08	HORIZONTAL CROSS BEAM	4 X 4 X 1/4 WALL TUBING	-
1	7	-07	DECK EXTENSION SUPPORT BEAM	4 X 4 X 1/4 WALL TUBING	-
1	6	-06	DECK SHORT SUPPORT BEAM	4 X 4 X 1/4 WALL TUBING	-
1	5	-05	DECK SUPPORT BEAM	4 X 4 X 1/4 WALL TUBING	-
5	4	-04	VERTICAL LEG PAD	A36 PLATE	-
5	3	-03	SANE CHERENKOV SUPPORT LEG	A500 STEEL	-
1	2	-02	SANE CHERENKOV SUPPORT STAND WELDMENT	4 X 4 X 1/4 WALL TUBING	-
1	1	-01	SANE CHERENKOV SUPPORT STAND ASSY	-	-

-01 SANE CHERENKOV SUPPORT STAND ASSY  
SCALE 1/10

APPROVALS	DATE	DOCUMENT CONTROL STATE	FINISH	IN USE	THIRD ANGLE PROJECTION	APPROVALS	DATE	REVISION NO.	NOTES
			113	0				67504-00007	
			113	0				67504-00007	
			113	0				67504-00007	
			113	0				67504-00007	
			113	0				67504-00007	
			113	0				67504-00007	

APPROVALS	DATE	DOCUMENT CONTROL STATE	FINISH	IN USE	THIRD ANGLE PROJECTION	APPROVALS	DATE	REVISION NO.	NOTES
			113	0				67504-00007	
			113	0				67504-00007	
			113	0				67504-00007	
			113	0				67504-00007	
			113	0				67504-00007	
			113	0				67504-00007	

SALENSON Lab  
Department of Energy

HALL C  
SANE EXPERIMENT  
CHERENKOV SUPPORT STAND

67504-00007

REV 1 of 3