

# SHMS Q2Q3Dipole Acceptance Test Plans

Paul Brindza

# Outline Q2Q3D Testing

- Magnet assembly process and resources
- Magnet assembly testing
- Acceptance Testing
- Acceptance Criteria

# Magnet Arrival Actions and Resources

- Magnet Arrival
  - Uncrating and Inspection at Port of Norfolk by SigmaPhi and Hall C engineering
  - Download shock recorder at Port of Norfolk
  - Magnet Delivery to Hall C floor is by contractor and is SigmaPhi's responsibility
  - Contractor is Lockwood Brothers for all three magnets
  - Delivery places the magnet on the Hall C floor
- Magnet Arrival Hall C/JLAB
  - Simple arrival tests and electrical exam by Hall C Engineering
  - JLAB alignment group – one day for fiducialization

# Heavy Installation and Resources

- Heavy Installation - all activities are serial
  - Q2Q3 rigging and installation on SHMS by Hall C Tech Crew
  - Dipole due to weight has rigging onto SHMS by Lockwood Bros.
  - Yoke re-assemblies by Hall C Tech crew
  - Replace access platform around magnet CCR Hall C Tech Crew
  - Remove shipping pins and flanges Hall C Tech Crew
  - Install Vacuum blank covers and pump flanges Hall C Tech Crew
  - Install vacuum pumps and start pump down Hall C Tech Crew

# Magnet Checkout and Resources

- Magnet Checkout- requires system experts
  - Leak and Pressure test – Hall C Engineering
  - Hipot coil and electrical check of sensors-Hall C Engineering
  - Install valve actuators and calibrate- Hall C Tech (1)
  - Connect I&C cables, DC bus- Spectrometer Support group
  - Check Instrumentation and controls-Hall C Engineering & Hall C Tech
  - Dry LHE space with warm N2 gas- Hall C Tech (1)
  - Connect cryogas lines- Hall C Techs (2)
  - Flow purge with He gas from ESR - Hall C Tech (1)
  - Install U-tubes ESR- Hall C Techs, ESR operator & Hall C Engineering

# Dipole Only Chimney Assembly and Resources

- Dipole Chimney Assembly
  - Install platform on Dipole yoke- Hall C tech crew
  - Install shield house roof- Hall C tech crew
  - Install CCR stand & CCR and Align- Hall C tech crew
  - Close Shield roof- Hall C tech crew
  - **Splice SC Bus- SigmaPhi (1) and Hall C tech (1)**
  - **Install I&C cables- SigmaPhi (1) and Hall C tech(1)**
  - Hipot coil and elec tests- Hall C Engineering
  - Weld LHe and LN2 tubes- Hall C welder(1) & Tech (1)
  - Install MLI and shield- Hall C tech (2)
  - Install chimney vacuum can and weld- Hall C welder(1) and Tech (1)
  - Evacuate Dipole- Hall C tech (1)
  - Leak and pressure test- Hall C Engineering

# Magnet Cool Down and Resources

- Magnet Cool Down-duration 2-3 weeks
  - Entire Cool Down is managed by PLC Controls
  - Cool to 80 K Requires Helium gas , LN2 & electricity
  - Humans monitor remotely – ESR operator & Hall C Engineering
  - Transition to LHE cooling at ~100K by PLC control
  - Bottom fill of Magnet by PLC Control
  - Transition to top fill by PLC Control
  - Transition to warm return by PLC Control
  - Liquid Level regulation by PLC Control
  - Tune up Liquid Level PID loops – Hall C Engineering

# Magnet Testing and Resources

- Magnet Testing requires system experts
  - Verify cryogenic regulation –Hall C Engineering
  - Controls and Instrumentation check out -Hall C Engineering
  - DCPS check out -Hall C Engineering
  - Quench Detector calibration- -Hall C Engineering
  - Low power ~ 10% magnet tests – SigmaPhi & Hall C Engineering
  - Progressive excitation to higher power – SigmaPhi & Hall C Engineering
  - Adjustment of support rods as needed –SigmaPhi & Hall C Engineering
  - Celebrate - everyone



# Q2Q3D Commissioning Tests

- Initial magnet tests on SHMS after installation
  - Hipot magnet DC circuit to 500 Volts
  - Electrical checkout all instrumentation for isolation and sensor function
  - He Mass Spec Leak test of LHE and LN2
  - Pressure test to 6 Bar
- Intermediate magnet tests of I&C – validate all sensors and equipment
  - Connect I&C cables to PLC
  - Voltage taps ( Dipole 16 plus spares, Quads 36 plus spares)
  - Thermometers, LNE(8) & LN2(8)
  - Cryogenic valve function ( 5 each magnet) and stroke calibration
  - Vacuum and pressure gauges ( Vac, LHE, LN2)
  - Liquid level probes ( LHE&LN2)

# Q2Q3D Commissioning Tests

- Cryogenic tests
  - Decontamination of LHE space 1 PPM water, ~10 PPM N<sub>2</sub>
  - Connect cryo gas return lines and DC bus
  - Circulate warm He gas back to ESR typically for 24 hours to validate contamination levels
  - Connect LHE and LN<sub>2</sub> supply U-tubes
- Cool Down First Stage
  - Target Temp < 100K
  - Use PLC controlled Helium gas coolant
  - Delta Temp in magnet < 50 K
  - He Coolant ~ 50 K < Magnet temp
  - Process uses a local PLC controlled heat exchanger to make any temperature He gas between 250 K and 80 K by blending 80 K Helium gas with 300 K He gas

# Q2Q3D Commissioning Tests

- Cool down second stage
  - Require Magnet temp  $< 100\text{K}$
  - Introduce LHe to magnet thru “Bottom fill” manifold in coil
  - Reduce temperature to 4.2 K
  - Fill magnet and CCR reservoir with Liquid Helium
  - Transition to cold return
  - Transition to “top fill”
  - Regulate liquid level ( LHE & LN2) with PLC

# Q2Q3D Commissioning Tests

- Low power tests
  - Check out I&C at 4.2 K
  - Check out cryogenic controls for stability
  - Validate all sensor functions
  - Calibrate quench detector ~ 10 millivolt sensitivity
  - Verify DC circuit isolation
  - Operate up to ~ 400 Amps (10%) to validate DCPSU, QD, Voltage Taps
  - Verify support rod strain gauges at acceptable stress
  - Adjust magnet center if necessary
  - Magnets centers must remain within +/-3 mm of true magnetic center

# Q2Q3D Magnet High Power Tests

- Progressive excitation in current steps( next table)
  - Ramp magnet to target current
  - Verify voltage taps
  - Verify support rod strain measurements
  - Verify Quench Detector sensitivity and balance
  - Ramp down and adjust coil if necessary
  - Soak at target current for one hour
  - Slow ramp down
  - Ramp up to target current and fast dump
  - Repeat at next current step

# Q2Q3D High Power Test Matrix

% Iop	Itest Amps	Stored Energy	CL Mass flow	PSU Output Voltage	PSU Ramp Rate	Dump Resistor Temp (after FD)	Helium Pressure (after FD)	Magnet Temp (after FD)
	Amps	MJoules	SLPM	Volts	A/sec	C	ATM	K
0	0	0	138					
10	345	0.16	144					
25	863	1.00	154					
50	1725	4.00	170					
75	2588	9.00	186					
100	3450	16.0	201					
103	3554	17.0	203					

SHMS Dipole Test Matrix

% Iop`	Current	Stored Energy (SE) % of MOP	CL Mass flow Setting	PSU Output Voltage	PSU Ramp Rate	Dump Resistor Temperature (after FD)	Helium Pressure (after FD)	Magnet Temperature (after FD)
	Amps	MJoules	SLPM He gas	Volts	A/sec	C	ATM	K
0	0	0	138					
10	366	0.10	145					
25	915	0.63	155					
50	1830	2.50	172					
75	2745	5.63	189					
100	3660	10.0	205					
109	4000	12.0	212					

SHMS Q2Q3 Test matrix

# Acceptance Criteria Q2Q3D

- Magnets shall meet design requirements( see table)
- Magnets shall operate with
  - Acceptable current ( 103 % dipole, 109% Q2Q3)
  - Acceptable Heat Leak (  $Q_{He} < 40w$  ,  $Q_{LN2} < 100w$  )
  - Acceptable insulating vacuum leak rate (  $LR < 10^{-9}$  )
  - Acceptable magnetic multipoles (see table)
  - Acceptable Instrumentation function ( see table)
  - Acceptable magnetic center (  $< 3mm$  )
- No requirement for training quenches
- No requirement for PLC, DCPSU, QD, QP, CCR

# Design requirements

Nominal DIPOLE Maximum Field	T	4.25
Required field orientation		Horizontal
Required Integral Field Strength	T-M	12.3
EFL(nominal RD)	m	2.90
Required Coil Radius (cold)	m	0.36
Required NI Total	Kilo Amp-Turns	3,918
Required Reservoir hold time	time	1 hour
Required cool down time	time	10 days
Coil voltage isolation	volts	500 V

Nominal Q2Q3 Gradient Max	T/m	14.4
Required Field orientation		Normal
Nominal EFL	m	1.61
Required coil Radius (cold)	m	0.36
B(r=pole)	T	5.184
Required Integral Grad strength	T/M -M	23.2
Required NI Total	Kilo-Amps-turns	7,940
Required Reservoir hold time	time	1 hour
Required cool down time	time	10 days
Coil Voltage isolation		500 V



# Multipole tables

Maximum Integral Harmonics Dipole		
$\int B_{(1)}$	Dipole	100 %
$\int B_{(3)}/B_{(1)}$	Sexapole	+ 2.0 %
$\int B_{(5)}/B_{(1)}$	Decapole	- 1.0 %
$\int B_{(7)}/B_{(1)}$	Tetradecapole	+ 0.5 %
$\int B_{(9)}/B_{(1)}$	Octaadecapole	-0.5 %
$\sum \int B_{(n>9)}/B_{(1)}$	All Others	0.1 %

Maximum Integral Harmonics Q2Q3		
$\int B_{(2)}$	Quadrupole	100 %
$\int B_{(3)}/B_{(2)}$	Sexapole	0.10 %
$\int B_{(4)}/B_{(2)}$	Octapole	-0.05 %
$\int B_{(6)}/B_{(2)}$	Dodecapole	-0.3 %
$\int B_{(8)}/B_{(2)}$	Hexadecapole	0.01 %
$\int B_{(10)}/B_{(2)}$	Icosapole	-0.10 %
$\sum \int B_{(n>10)}/B_{(2)}$	All Others	0.05 %

# Q2Q3D instrumentation Table

	Dipole	Quad	D spares	Q spares	type
Voltage taps	8	18	8	18	
HE temp sensors	4	4	4	4	Cernox
LN2 Temp sensors	4	4	4	4	PT100
Strain Gauges	8	8	8	8	2 axis

Note: CCR instrumentation by JLAB

# SHMS Magnet Operations

- Magnet Testing uses the same control system as routine operations for Experimental Physics
- PLC control is used
- PLC executes operators commands
- PLC displays, logs and graphs temp, strain, voltages, pressures
- PLC reacts to and logs interlocks
- Quench Detection is analogue and digital



Overview - /Hall\_C//SHMS

### SHMS

Using Standard Tune

	Fields	PO (GeV/c)	POL	I (A)	LHe (%)
HB	-5.013 KG	0.00015 E		0.0500	70.0
Q1	-30.342 KG	0.00019 E		0.0400	70.1
Q2	KG	0.10000 P		0.4400	-32
Q3	KG	0.10000 P		19.6000	3-4
D	0.00000 T	0.10000 E		0.0000	2-3

Power Supply is Ramping Down

PO Set (GeV/c) 0.100000 [Start] [Off]

---

### HMS

Using Non-Standard Tune

	Fields	PO (GeV/c)	POL	I (A)	LHe (%)
Q1	0.000 KG	0.00000 E		0.0000	70.0
Q2	0.000 KG	0.00000 E		0.0000	69.7
Q3	0.000 KG	0.00000 E		0.0000	69.9
D	0.48451 T	0.00000 P		0.1500	70.0

Power Supply is Ramping Down

PO Set (GeV/c) 0.000000 [Start] [Off]

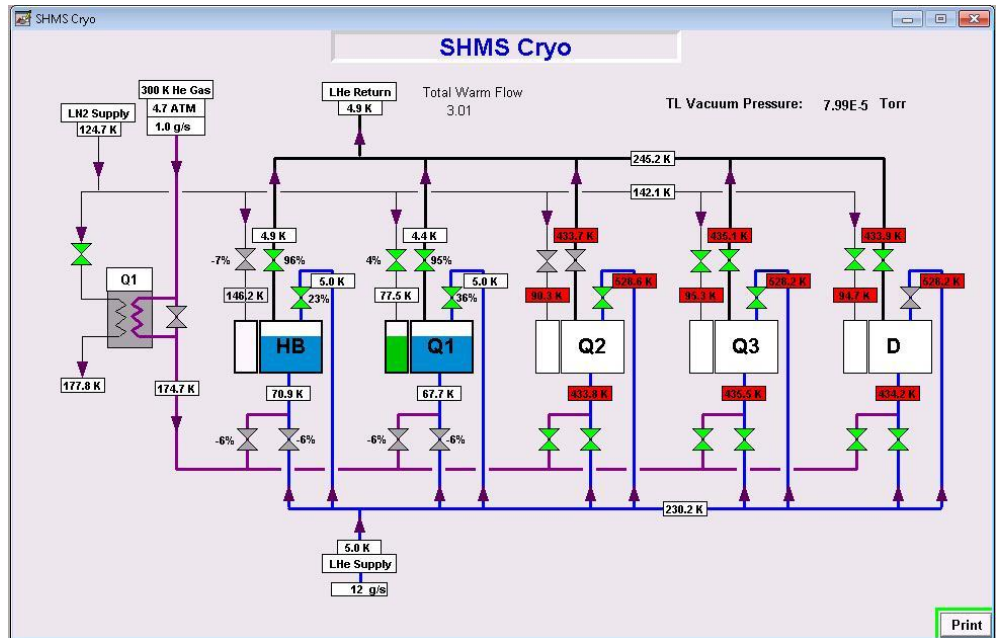

9/29/2016 11:42:45 AM

# SHMS Q2 PSU

Communication Error

**Set 000000    ADC 00011**

**Momentum  
Input Mode**

Momentum (GeV): 0.20000

399.3151 Amps

0.000 Output Voltage

**Polarity**

Electron

Proton

- Regulation Transformer not Zero
- Software Fast Discharge
- Software Slow Discharge
- One Transistor Fault
- Interlock Sum
- DC Overcurrent
- DC Overload

- Quench Interlock
- Preregulator Failure
- Phase Failure
- MPS Waterflow Failure
- Earth Leakage Failure
- Thermal Breaker / Fuses
- MPS Overtemperature
- Panic Button / Door Switch
- Magnet Waterflow Failure
- MPS Not Ready
- Dump Switch

I True: 0.44 Amps

**Hardware Status**

- 480 power
- Interlock Sum
- Main Power



# SHMS Q2 Helium Temp Screen

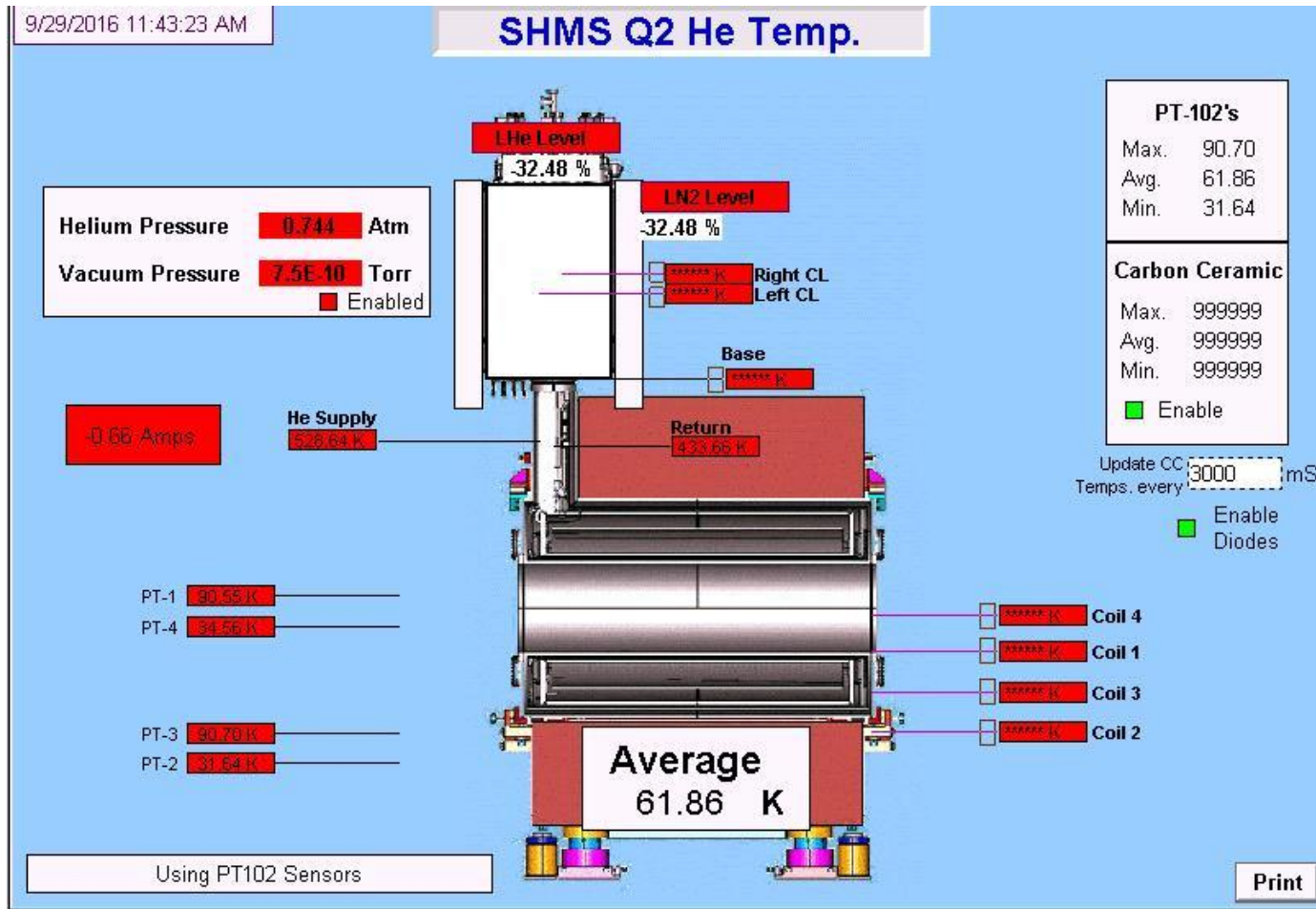

# SHMS Q2 Coil Voltages

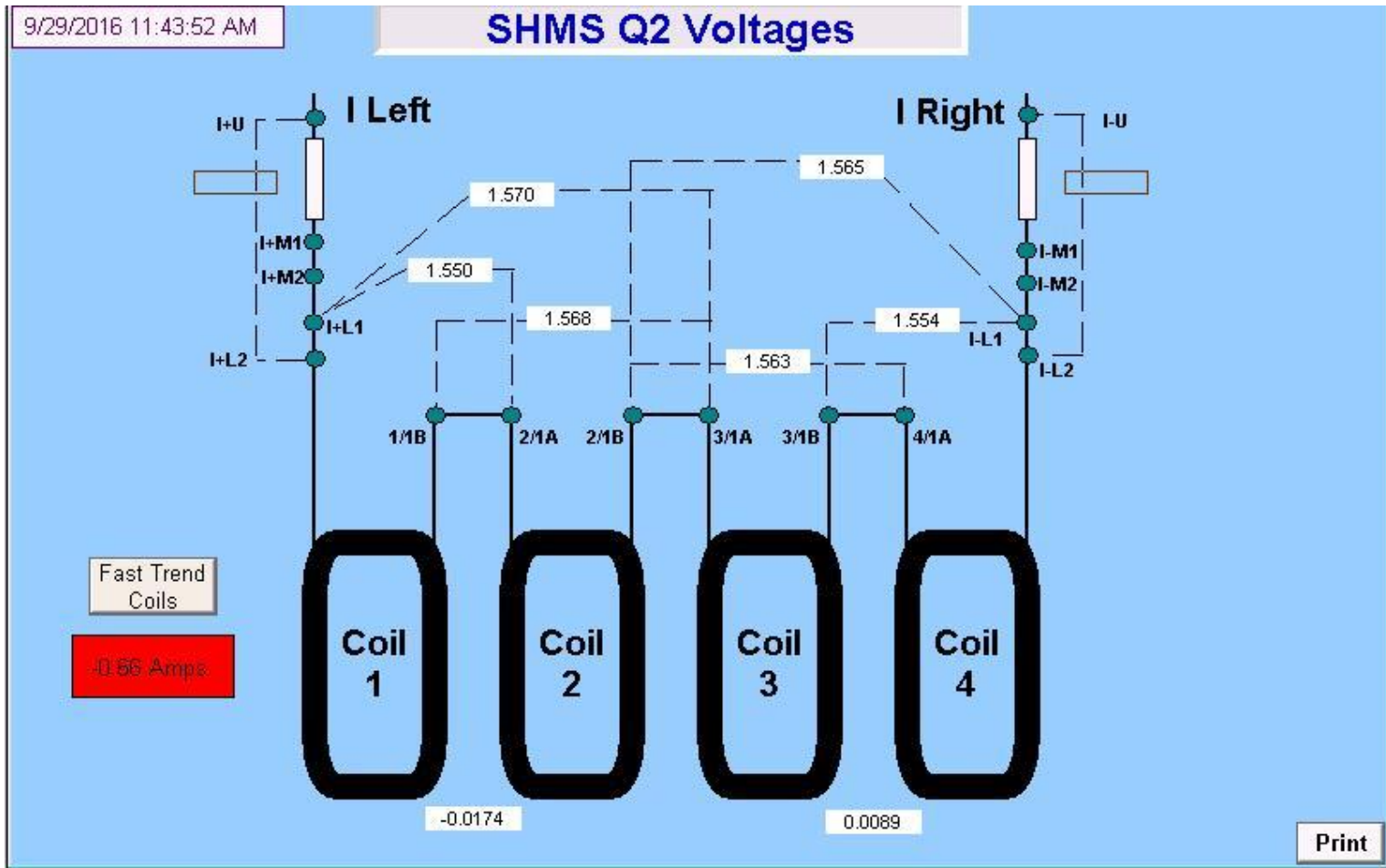



# SHMS Q2 Suspension Link Screen

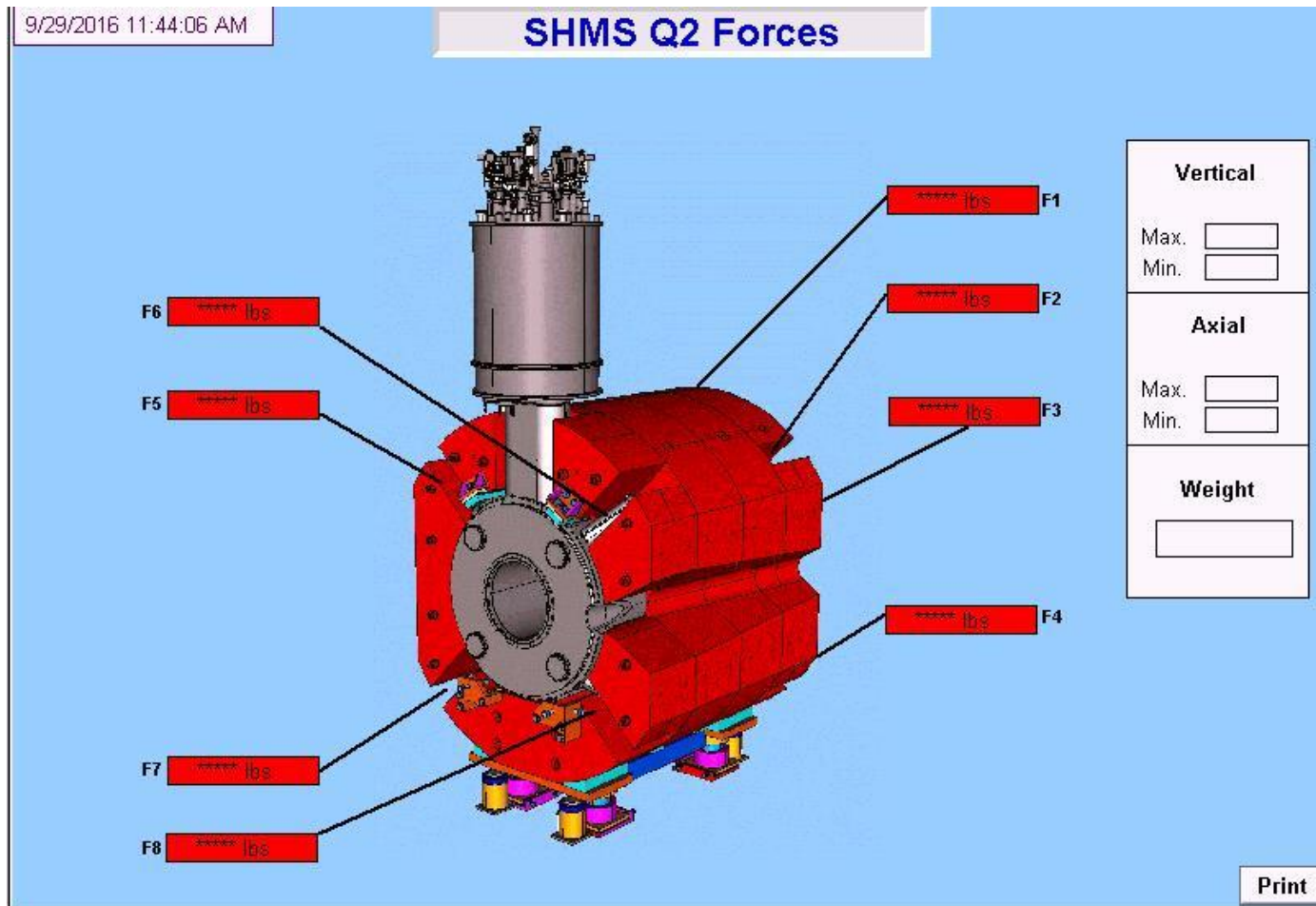

# SHMS Q2 Interlocks

9/29/2016 11:44:21 AM

## SHMS Q2 Interlock

Keep Alive Timer

Interlock  
 Fast Discharge  
 Slow Discharge

Fast Discharge by Operator

Slow Discharge by Operator

Hardware Quench Detector

<input type="checkbox"/> Coil 1	<input type="checkbox"/> Coil 2	<input type="checkbox"/> Coil 3	<input type="checkbox"/> Coil 4
<input type="checkbox"/> Coil 1	<input type="checkbox"/> Coil 2	<input type="checkbox"/> Coil 3	<input type="checkbox"/> Coil 4
<input type="checkbox"/> Coil 1 Fault	<input type="checkbox"/> Coil 2 Fault	<input type="checkbox"/> Coil 3 Fault	<input type="checkbox"/> Coil 4 Fault

Software Quench Detector  
 Coil 1  Coil 3  L CL  Left / Right  
 Coil 2  Coil 4  R CL

Left Current Lead  
 Chnnel 4 Upper  Chnnel 4 Lower  
 Chnnel U4 Fault  Chnnel L4 Fault

Right Current Lead  
 Chnnel 1 Upper  Chnnel 1 Lower  
 Chnnel U1 Fault  Chnnel L1 Fault

Current Lead Mass Flow  

Left Current Lead	Right Current Lead
<input type="checkbox"/> Flow too Low	<input type="checkbox"/> Flow too Low
<input type="checkbox"/> Flow Error	<input type="checkbox"/> Flow Error
<input type="checkbox"/> Flow Fault	<input type="checkbox"/> Flow Fault

Magnet Temperature  
 Coil1 Too High  Coil3 Too High  
 Coil2 Too High  Coil4 Too High  
 He Sensor Error  
 CC1 Error  CC4 Error  CC7 Error  
 CC2 Error  CC5 Error  
 CC3 Error  CC6 Error

Power Supply Interlock  
 Dump Switch Interlock

Force Interlock  
 Vertical  Max  Min  
 Axial  Max  Min

# SHMS Cool Down Control

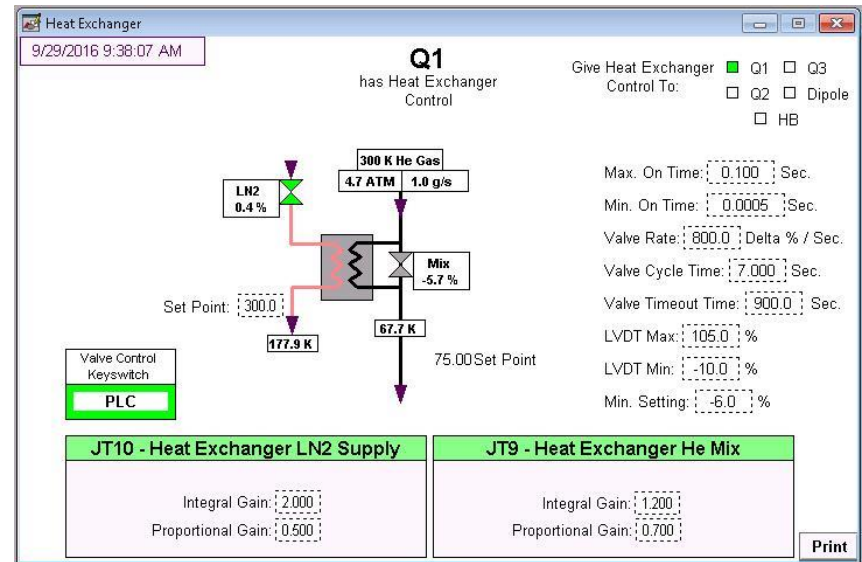
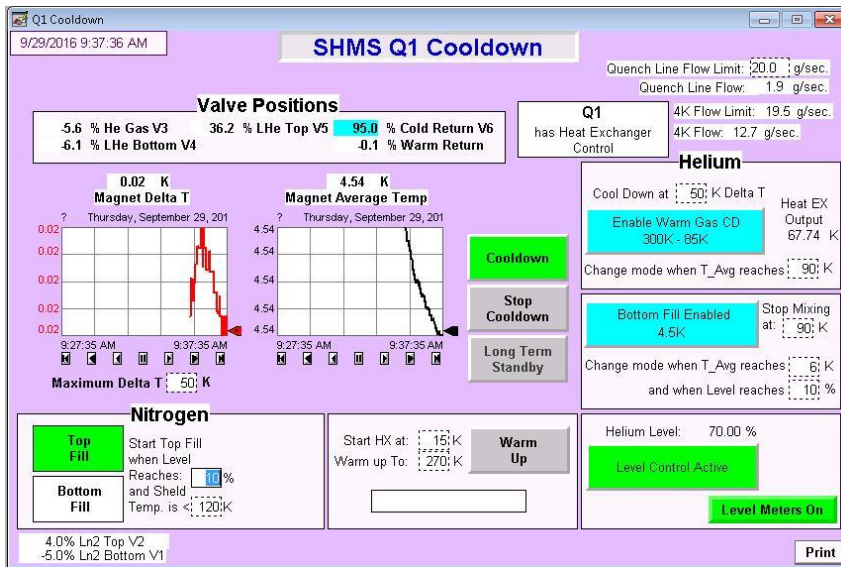

# Summary

- Dipole Q2Q3 are designed to spec. Passed
- Factory Electrical tests - Passed
- Max. Current, Heat Leak, Leak rate, Multipoles, Coil Isolation, Sensor function to be tested at JLAB
- PLC Control will be used to execute the Test Plan
- Test Plan procedure will permit safe testing of the Q2Q3D
- Your comments please?

# Appendix 1

## Q1 screen with actual data

October 12, 2016

# SHMS Magnet Cryogenic Screen

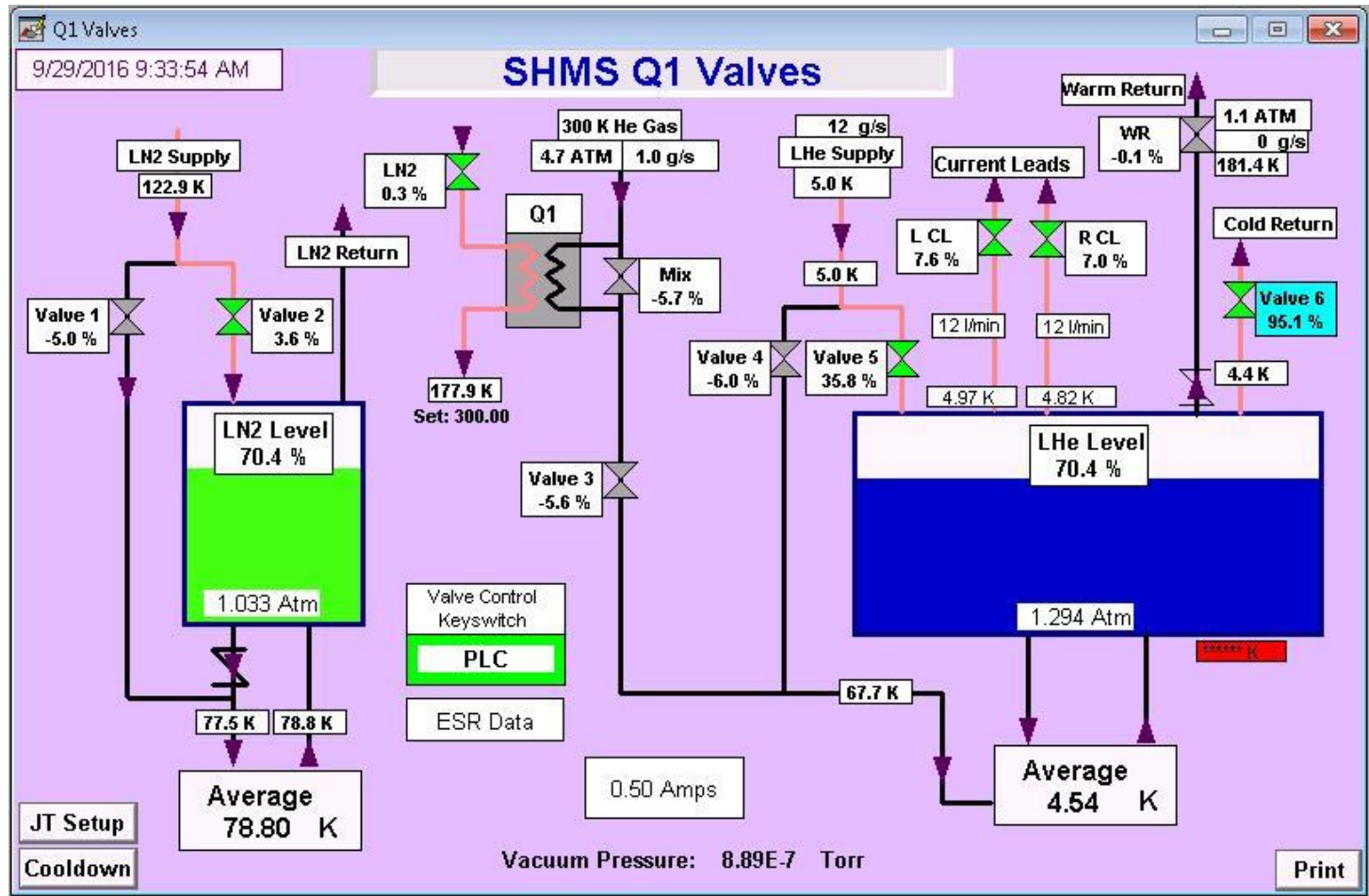

# SHMS Temperature Monitoring

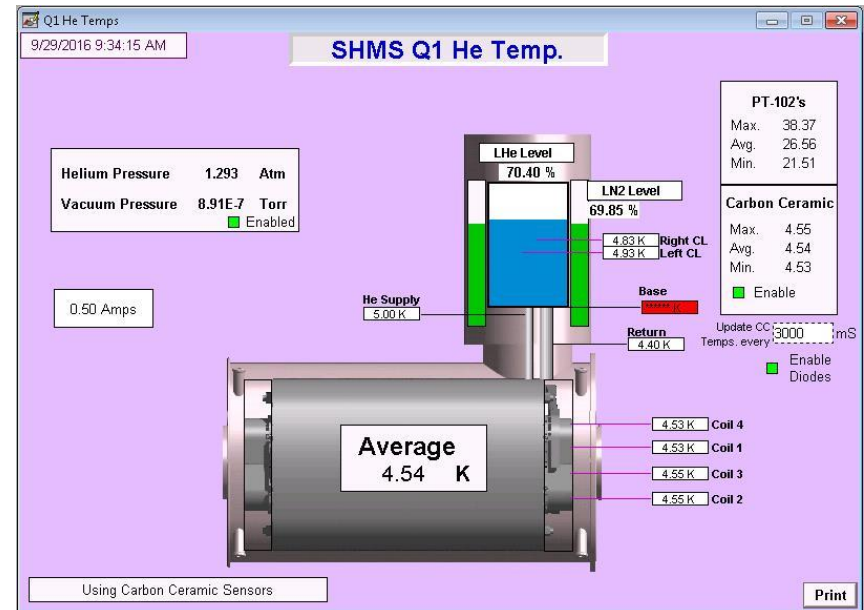
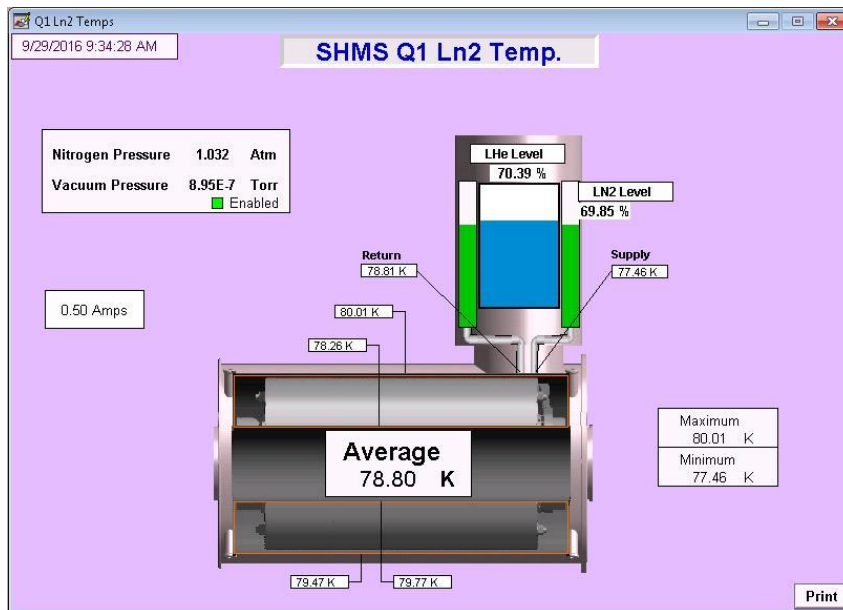

# Power Supply and coil voltages

